

# SPECIAL ROCK CUTTERS



English



**KEMROC<sup>®</sup>**

revolution of cutting

An innovative, German engineering company developing revolutionary excavator attachments – focused on product development, quality engineering and reliability.



Cutter attachments are our passion. With more than 25 years' experience, we develop and manufacture cutter attachments for excavators and backhoe loaders. Our attachments are robust and strong with main components made in Germany.

Together with our customers, we are constantly developing new solutions for demolition, construction, and mining applications. Challenge us! We guarantee specialist information and professional service for our products. Our international team of specialists will be happy to support you with your individual project.

Attention during production and assembly guarantees the highest level of quality and reliability.

Excellent Service. We support you, our team can help install your KEMROC attachment and train your operators.



Modern production facilities.

revolution of cutting

# CONTENT

	Page		Page
<b>FEATURES</b>		<b>EBA RANGE</b>	
Attachments for all trench sizes	4	Auger drive attachments for excavators and backhoe loaders	32
Cutting technology	5		
<b>EK RANGE</b>		<b>KTR RANGE</b>	
Chain cutters — reduce wear & tear on the excavator swing gear and save energy	6	Trenching attachments for medium hard rock	34
<b>EKT RANGE</b>		<b>KDS RANGE</b>	
Rotary drum cutters — can be converted into EK chain cutters	10	Diamond saws for a wide variety of applications and materials	36
<b>KR RANGE</b>		<b>KRM RANGE</b>	
Rotary drum cutters with spur gears	12	Rotation units with endless rotation	40
<b>KRD RANGE</b>		<b>NON-STANDARD MODELS</b>	
Rotary drum cutters with direct drive	16	Manufactured to order according to customer requirements	42
<b>KRC RANGE</b>		<b>KEMSOLID</b>	
Bullhead cutters with full-face coverage for narrow trenches	18	Special foundation solutions from Kemsolid Division—fast, efficient and environmentally friendly	44
<b>DMW RANGE</b>		<b>TOOLS</b>	
Cutter wheels with double motor for rock up to 140 MPa	20	Picks with matching retainers, pick boxes, diamond saw blades, mounting and dismantling tools	46
<b>KRX RANGE</b>		<b>HOLE PATTERNS</b>	
Powertool drives with attachments for milling, drilling and mixing	24	Hole patterns for KEMROC attachments	54
<b>EX RANGE</b>			
Patch planers for milling asphalt and concrete with accurate depth control	28		
<b>ES RANGE</b>			
Cutter heads for asphalt, concrete and rock	30		



# FEATURES

KEMROC cutter attachments work reliably and efficiently in almost any material. Steel, concrete, rock, wood – wherever KEMROC cutter attachments are used, material is removed safely and accurately.



## CUTTING TECHNOLOGY

When grinding with round attack picks, each tool penetrates into the rock along parallel paths and breaks material out from the space between the paths. The cutting rate depends to a large degree on the uniaxial compressive strength of the rock being cut. Other significant factors affecting production rates include the hydraulic pressure and flow that the excavator is able to supply to the attachment, as well as the stability and weight of the excavator.

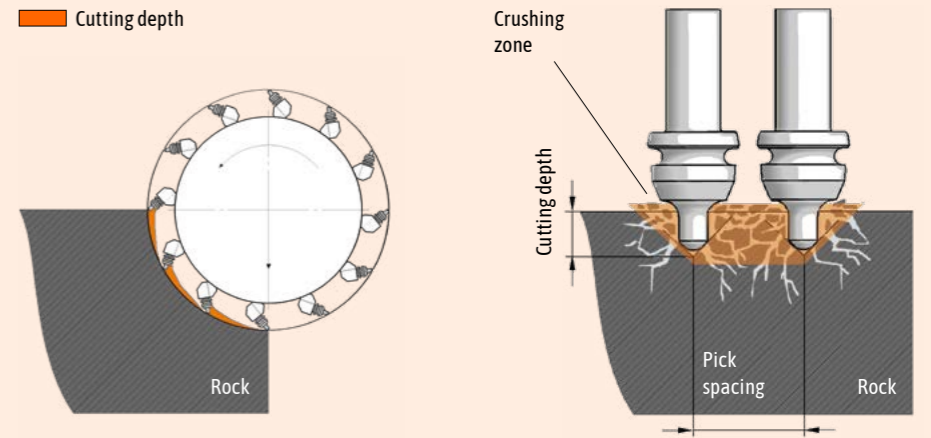

The experience gained from many years of cutting rock has gone into the design of the cutter wheels, drums and chains. They are designed to give maximum cutting performance with minimum wear costs. The selection of picks and boxes, as well as the design of the pick pattern, are part of our continuous product improvement.

## ATTACHMENTS FOR ALL TRENCH SIZES

Trenching attachments from KEMROC provide options for trench widths from 8 centimeters.

	Min. trench width mm	Max. trench width mm	Trench depth mm	Recommended excavator weight t	Max. uniaxial compressive strength MPa	Page
DMW Cutter Wheels	80	400	400–1,000	14–120	140	20
KTR Trenching Attachments	170	450	1,000–1,800	18–35	60	36
KRX Powertool Drives	370	550	100–3,000	5–50	140	24
EK Chain Cutters	390	–	100–8,000	2–70	140	6
EKT Rotary Drum Cutters	500	–	200–8,000	2–70	140	10
KRC Bullhead Cutters	530	–	200–8,000	7–80	140	18
KR Rotary Drum Cutters	500	–	200–8,000	0.6–125	180	12
KRD Rotary Drum Cutters	600	–	200–8,000	0.5–50	100	16





# EK RANGE

**Chain cutters — reduce wear & tear on the excavator swing gear and save energy**

 **2-70t**

The EK range of chain cutters are the first of their type on the market. Designed for use on excavators from 2 to 70 tons, they are ideal for cutting stone with an uniaxial compressive strength up to 140 MPa. They are efficient, vibration-free attachments for the excavation of deep narrow trenches with the optimal trench profile. Trench width starts from 390 mm. Another application is mining of medium hard minerals with compressive strength from 15 to 80 MPa, where drill and blast is not possible.

KEMROC chain cutters excavate trenches no wider than absolutely necessary. The continuous chain, driven by the cutter drums, removes the material automatically from the space between the cutter drums. With standard drum cutters, the need to remove this material on technical grounds always results in trenches wider than the cutter. Keeping trenches to the minimum width possible saves unnecessary transport costs for removal of cut material and fill material becomes cheaper. The material produced by the chain cutter is fine grained and is ideal for use as fill.

EK chain cutters reduce wear and tear on the excavator swing gear. In addition, they give a 40 percent energy saving for equivalent production rates compared to conventional rotary drum cutters without the central chain.



**EK 140**  
Trenching and  
pipeline work



## Chain cutters — reduce wear & tear on the excavator swing gear and save energy

Minimal wear on excavator as the method of operation eliminates need for swing motion

Needs approx. 40 percent less energy than equivalent drum cutter without a chain between the drums

Range of cutting widths available

		EK 20	EK 40	EK 60	EK 100	EK 110	EK 140	EK 150	EK 160	EK 220	EK 240
Recommended excavator weight	t	2–6	5–11	10–17	18–30	25–32	30–45	35–50	35–50	50–70	50–70
Rated power	kW	22	44	60	100	110	140	150	150	220	220
Cutter length (A)	mm	1,000	1,300	1,600	1,970	1,970	2,150	2,150	2,150	2,400	2,400
Cutting width (B)	mm	390	500	500 600	600 700 800	600 700 800	800 900 1,000	800 900 1,000	800 900 1,000	920 1,300	920 1,300 1,500
Cutter drum diameter (C)	mm	325	475	600	800	800	850	850	850	990	990
Recommended rotation speed	rpm	75	90	80	65	65	70	65	65	45	45
Recommended oil flow <sup>[1]</sup>	l/min	30	85	140	200	250	275	330	350	550	600
Max. oil flow <sup>[1]</sup>	l/min	70	115	195	260	300	320	390	425	650	650
Max. operating pressure	bar	400	400	400	400	400	400	400	400	400	400
Torque at 380 bar	Nm	2,400	5,700	10,900	18,900	24,500	25,400	30,300	34,000	72,700	78,400
Cutting force at 380 bar	kN	15	24	36	47	61	60	71	80	147	158
Max. rock compressive strength	MPa	25	30	50	80	80	100	100	120	140	140
Weight per cutting width	kg	315	750	1,250 1,300	2,450 2,510 2,620	2,450 2,510 2,620	3,650 3,700 3,800	3,650 3,700 3,800	3,650 3,700 3,800	5,900 6,800	5,900 6,800 7,200
Tool holder / pick box	Type	PH14	PH20	PH22	PH32HD	PH32HD	PH32HD	PH32HD	PH32HD	PH38HD	PH38HD
Number of picks in cutter drums	Pcs	56	52	40 60	28 40 48	28 40 48	44 48 56	44 48 56	44 48 56	44 72	44 72 84
Number of picks in the cutter chain	Pcs	54	49	53	54	54	63	63	63	58	58
Standard pick <sup>[2]</sup>	Type	1	2	3	4	4	4	4	5	6	6
Standard hole pattern <sup>[3]</sup>	Type	LB10	LB10	LB20	LB30	LB30	LB40	LB40	LB40	LB40	LB40
Compatible rotation unit	Type	KRM30	KRM35	KRM40	KRM50	KRM60	KRM60	KRM60	KRM70	KRM80	KRM80

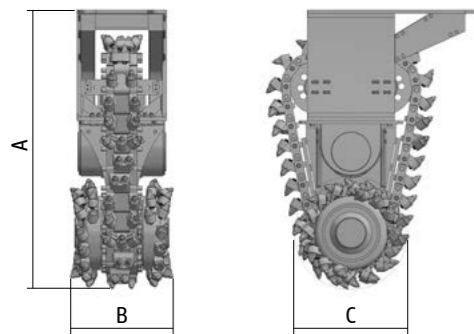

- 1 ER 15/29/26/14 C
- 2 ER 16/46/38/20 C
- 3 ER 15/46/38/22 C
- 4 ER 17/75/70/30 Q
- 5 ER 19/75/70/30 Q
- 6 ER 25/80/80/38 C

- [1] Setting the correct oil flow ensures that maximum output power is never greater than the rated power at any pressure level.
- [2] For an overview of standard picks, see pages 49 to 51. Depending on application, cutter heads can be supplied with a choice of pick according to the type of pick box used.
- [3] An overview of hole patterns can be found on page 54.

The EK range is patent protected.

Fine grained cut material  
Low noise and vibration levels

Works underwater without need for modifications

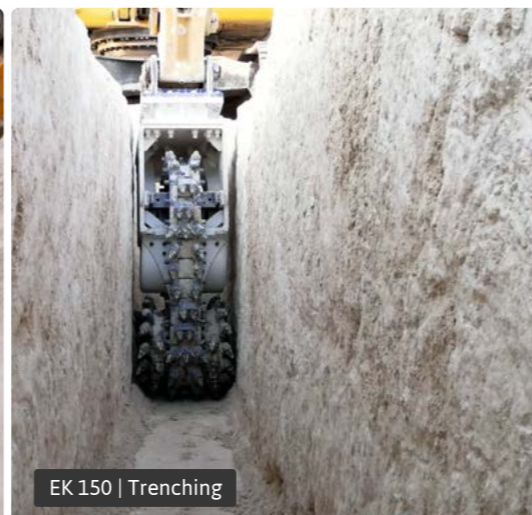

### APPLICATIONS

Trenching and pipeline work  
Mining of soft to medium hard minerals  
Can also be used for concrete renovation, profiling, underwater excavations and tunnelling

Additional applications in KEMROC Projector



[projector.kemroc.net/web/?range=ek](http://projector.kemroc.net/web/?range=ek)



# EKT RANGE

## Rotary drum cutters — can be converted into EK chain cutters

 2–70 t



The patented EK range of chain cutters are one of our core products and continues to be recommended as an ideal tool for trenching contractors. This concept is being expanded with the addition of the new EKT range of

traditional style drum cutters. These lower priced models are supplied as rotary drum cutters without a central cutting chain, but conversion kits are available so that cutter chains can be fitted later.

**+** Can be converted to an EK model  
**Fast and strong**

Converts from a rotary drum cutter to a chain cutter and vice versa.

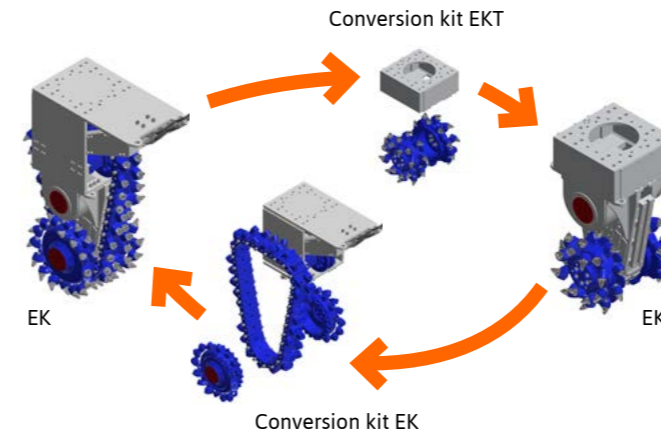

**EKT 20**   **EKT 40**   **EKT 60**   **EKT 100**   **EKT 110**   **EKT 140**   **EKT 150**   **EKT 160**   **EKT 220**   **EKT 240**

	t	2–6	7–11	12–17	18–30	25–32	30–45	35–50	35–50	50–70	50–70
Recommended excavator weight	t	2–6	7–11	12–17	18–30	25–32	30–45	35–50	35–50	50–70	50–70
Rated power	kW	22	44	60	100	110	140	150	150	220	220
Cutter length (A)	mm	540	1,000	1,190	1,460	1,460	1,540	1,540	1,540	1,760	1,760
Cutting width (B)	mm	410	500	500 600	700 800	700 800	880	880	880 1,040	920 1,300	920 1,300
Cutter drum diameter (C)	mm	225	445	590	690	690	720	720	720	860	860
Recommended rotation speed	rpm	75	90	80	65	65	70	65	65	45	45
Recommended oil flow <sup>[1]</sup>	l/min	30	85	140	200	250	275	330	350	550	600
Max. oil flow <sup>[1]</sup>	l/min	70	115	195	260	300	320	390	425	650	650
Max. operating pressure	bar	400	400	400	400	400	400	400	400	400	400
Torque at 380 bar	Nm	2,400	5,700	10,900	18,900	24,500	25,400	30,300	34,000	72,700	78,400
Cutting force at 380 bar	kN	21	26	37	55	71	71	84	94	169	182
Max. rock compressive strength	MPa	25	30	50	80	80	100	100	120	140	140
Weight per cutting width	kg	130	430	725 775	1,300 1,360	1,300 1,360	2,000	2,000	2,000 2,500	3,100 3,550	3,100 3,550
Tool holder / pick box	Type	PH14	PH20	PH22	PH32 HD	PH32 HD	PH32 HD	PH32 HD	PH32 HD	PH38 HD	PH38 HD
Number of picks per cutting width	Pcs	56	52	40 60	40 44	40 44	44	44	44 56	44 60	44 60
Standard pick <sup>[2]</sup>	Type	1	2	3	4	4	4	4	5	6	6
Standard hole pattern <sup>[3]</sup>	Type	LB10	LB10	LB20	LB30	LB30	LB40	LB40	LB40	LB40	LB40
Compatible rotation unit	Type	KRM30	KRM35	KRM40	KRM50	KRM60	KRM60	KRM60	KRM70	KRM80	KRM80

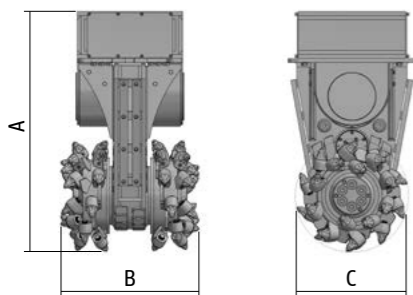

- 1 ER15/29/26/14 C
- 2 ER16/46/38/20 C
- 3 ER15/46/38/22 C
- 4 ER17/75/70/30 Q
- 5 ER19/75/70/30 Q
- 6 ER25/80/80/38 C

<sup>[1]</sup> Setting the correct oil flow ensures that maximum output power is never greater than the rated power at any pressure level.  
<sup>[2]</sup> For an overview of standard picks, see pages 49 to 51. Depending on application, cutter drums can be supplied with a choice of pick according to the type of pick box used.  
<sup>[3]</sup> An overview of hole patterns can be found on page 54.

**+**

- Two motors for extra hydraulic power
- Tough, rigid gearbox housing
- Drums supported on robust bearings
- Protection for hydraulic hoses
- Works underwater without need for modifications



### APPLICATIONS

Trenching and pipeline work

Mining of soft to medium hard minerals

Can also be used for concrete renovation, profiling, underwater excavations and tunnelling



Additional applications in KEMROC Projector

[projector.kemroc.net/web/?range=ekt](http://projector.kemroc.net/web/?range=ekt)

# KR RANGE

## Rotary drum cutters with spur gears

 0.6–125 t

In addition to standard EK and the convertible EKT range, traditional style rotary drum cutters are now also available from KEMROC. They are designated as the new KR range of drum cutters. Designed to be incredibly robust, these attachments are ideal for use on short arm excavators working in confined spaces, especially in tunnelling and also for the vibration free and silent demolition of reinforced concrete structures.

Effective dust control is particularly important in demolition and tunnelling applications. The KR range of cutters are designed for the installation of an optional, hydraulically controlled water jet dust control system.



**KR 150**  
Concrete  
demolition



## Rotary drum cutters with spur gears

**Extra heavy-duty, rigid gear box housing**

Exceptional wear protection on the gearbox

**Equipped for optional water spray dust suppression system**

High torque motors for maximum cutting force

**Drums supported on heavy-duty bearings**

Protected hose management

Works underwater without need for modifications

KR 10 KR 15 KR 18 KR 20 KR 35<sup>[1]</sup> KR 45 KR 50 KR 65 KR 70 KR 80 KR 90

KR 110<sup>[1]</sup> KR 120<sup>[1]</sup> KR 150<sup>[1]</sup> KR 155 KR 165<sup>[1]</sup> KR 175<sup>[1]</sup> KR 200 KR 250 KR 400<sup>[1]</sup> KR 450<sup>[1]</sup>

Recom. excavator weight	t	0.6-3	0.6-3	2-4	2-4	5-8	9-15	9-15	12-18	15-23	15-25	15-25	20-35	25-45 [20-40]	30-50	30-50	35-55	40-55	50-70	60-80	80-125	100-125
Rated power	kW	10	15	18	18	30	45	45	65	70	80	80	110	120	120	120	160	160	200	200	400	400
Cutter length (A)	mm	490	490	490	500	845	990	1,014	1,195	1,195	1,235	1,235	1,470	1,470	1,470	1,470	1,590	1,590	1,660	1,660	2,050	2,050
Cutting width (B)	mm	425	425	425	495	620 [520]	600	690	805	805	805	805	1,040 [880]	1,040 [880]	1,040 [880]	1,040	1,250 [1,050]	1,250 [1,050]	1,330	1,330	1,650 [1,300]	1,650 [1,300]
Cutter drum diameter (C)	mm	225	225	225	240	370	400	450	587	587	587	587	720	720	720	720	720	720	825	825	950	950
Recom. rotation speed	rpm	95	115	115	100	115	105	95	70	70	70	65	70	70	65	65	65	55	50	60	45	45
Recommended oil flow <sup>[2]</sup>	l/min	15	20	40	35	85	105	95	145	175	185	210	225	320	330	340	380	400	430	580	885	1045
Max. oil flow <sup>[2]</sup>	l/min	40	45	90	85	115	145	130	170	190	210	240	250	360	360	360	400	420	525	600	1200	1200
Max. operating pressure	bar	400	400	400	400	400	400	400	400	400	400	400	400	400	400	400	400	400	400	400	400	400
Torque at 380 bar	Nm	900	1,000	2,100	2,100	4,400	6,100	6,100	12,300	14,700	15,700	19,500	19,000	27,200	29,800	32,700	36,400	43,000	51,000	60,000	121,500	143,000
Cutting force at 380 bar	kN	8.3	9.2	18.8	17.6	23.9	30.7	27.3	41.8	50.1	53.6	66.4	52.7	75.6	82.7	90.7	101.1	119.4	123.3	145.3	255.3	301.0
Max. rock compressive strength	MPa	20	20	20	20	30	40	40	60	70	80	80	90	100	100	100	110	110	140	140	180	180
Weight	kg	103	103	103	130	375 [310]	500	550	900	900	1,070	1,070	2,050 [1,850]	2,050 [1,850]	2,050 [1,850]	2,050	2,800 [2,550]	2,800 [2,550]	3,720	3,720	7,100 [6,300]	7,100 [6,300]
Tool holder / pick box	Type	PH14	PH14	PH14	PH14	PH20	PH20	PH22	PH30 HD	PH30 HD	PH30 HD	PH30 HD	PH32 HD	PH32 HD	PH32 HD	PH32 HD	PH32 HD	PH32 HD	PH38 HD	PH38 HD	PH38 HD	PH38 HD
Number of picks	Pcs	44	44	44	56	64 [44]	44	44	44	44	44	44	60 [44]	60 [44]	60 [44]	60	64 [60]	64 [60]	64	64	88 [68]	88 [68]
Standard pick <sup>[3]</sup>	Type	1	1	1	1	2	2	3	4	4	4	4	5	5	5	6	6	6	7	7	7	7
Standard hole pattern <sup>[4]</sup>	Type	LB10	LB10	LB10	LB10	LB10	LB20	LB20	LB20	LB20	LB30	LB30	LB40	LB40	LB40	LB40	LB40	LB40	LB40	LB40	LB50	LB50
Compatible rotation unit	Type	KRM30	KRM30	KRM30	KRM30	KRM35	KRM40	KRM40	KRM40	KRM40	KRM40	KRM50	KRM60	KRM60	KRM60	KRM60	KRM60	KRM70	KRM70	KRM80	KRM80	—

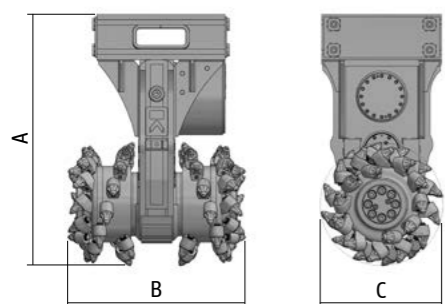

- 1 ER 15/29/26/14 C
- 2 ER 16/46/38/20 C
- 3 ER 12/45/38/22 HC
- 4 ER 17/75/70/30 Q
- 5 ER 19/75/70/30 Q – on KR 110 | 120 | 150  
ER 17/75/70/30 Q – on KR 110 C | 120 C | 150 C
- 6 ER 19/75/70/30 Q
- 7 ER 25/80/80/38 C

<sup>[1]</sup> Also available in a C version with smaller cutting width under model designation KR 35 C, KR 110 C, KR 120 C, KR 150 C, KR 165 C, KR 175 C, KR 400 C bzw. KR 450 C. Revised values for this C version shown in square brackets.

<sup>[2]</sup> Setting the correct oil flow ensures that maximum output power is never greater than the rated power at any pressure level.

<sup>[3]</sup> For an overview of standard picks, see pages 49 to 51. Depending on application, cutter drums can be supplied with a choice of pick according to the type of pick box used.

<sup>[4]</sup> An overview of hole patterns can be found on page 54.



### APPLICATIONS

Tunnelling  
Demolition

Also used for trenching and pipeline work, renovating concrete, profiling, mining of soft minerals and underwater excavation

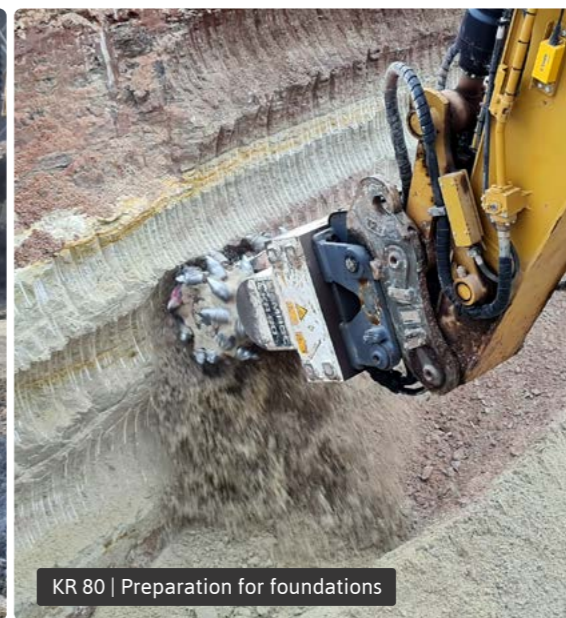
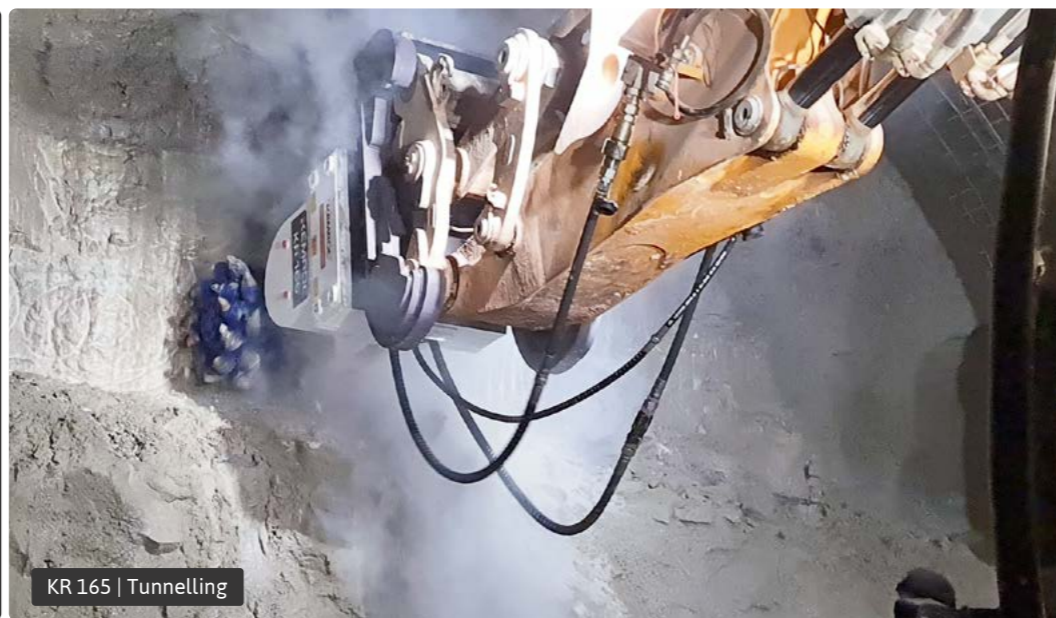

Additional applications in KEMROC Projector

[projector.kemroc.net/web/?range=kr](http://projector.kemroc.net/web/?range=kr)

# KRD RANGE

## Rotary drum cutters with direct drive

 0.5–50 t



**Strong, compact design**

**Direct drive with particularly strong support for the cutter drums**

**High power to weight ratio**

**Protected hose management**

**Operational to 30 meters underwater without need for modifications**

The KRD range of direct drive drum cutters can be described as compact, lightweight but strong. Lighter and shorter, these attachments are ideal for use on long-arm excavators for

demolition and shaft sinking applications. They can also be used for soil stabilisation and concrete renovation applications. Intentionally oversized bearings have been used to support

the cutter drums for a long operating life.

**KRD 15   KRD 18   KRD 30   KRD 45   KRD 70   KRD 100   KRD 120   KRD 150   KRD 155   KRD 165   KRD 175**

		KRD 15	KRD 18	KRD 30	KRD 45	KRD 70	KRD 100	KRD 120	KRD 150	KRD 155	KRD 165	KRD 175
Recommended excavator weight	t	0.5–2	2–4	5–8	9–16	17–25	20–40	25–40	30–40	30–40	35–50	35–50
Rated power	kW	15	18	30	45	70	110	120	120	120	160	160
Cutter length (A)	mm	511	511	588	670	951	1,070	1,070	1,070	1,070	1,072	1,072
Cutting width (B)	mm	500	500	629	743	946	1,020	1,020	1,020	1,020	1,260	1,260
Cutter drum diameter (C)	mm	300	300	370	447	612	742	742	742	742	725	725
Recommended rotation speed	rpm	145	115	110	110	75	70	70	65	65	65	55
Recommended oil flow <sup>[1]</sup>	l/min	25	40	80	110	200	225	320	330	340	380	400
Max. oil flow <sup>[1]</sup>	l/min	40	65	100	130	230	250	360	360	360	400	420
Max. operating pressure	bar	400	400	400	400	400	400	400	400	400	400	400
Torque at 380 bar	Nm	1,000	2,100	4,400	6,100	16,300	19,000	27,200	29,800	32,700	36,400	43,000
Cutting force at 380 bar	kN	6.9	14.1	23.9	27.5	53.4	51.1	73.4	80.2	88.0	100.4	118.6
Max. rock compressive strength	MPa	20	20	30	40	80	90	100	100	100	110	110
Weight	kg	135	135	250	380	850	1,400	1,400	1,400	1,400	1,850	1,850
Tool holder / pick box	Type	PH14	PH14	PH20	PH22	PH30 HD	PH30 HD	PH30 HD	PH30 HD	PH30 HD	PH30 HD	PH30 HD
Number of picks	Pcs	66	66	56	46	40	48	48	48	48	64	64
Standard pick <sup>[2]</sup>	Type	1	1	2	3	4	4	4	4	4	5	5
Standard hole pattern <sup>[3]</sup>	Type	LB10	LB10	LB10	LB20	LB30	LB40	LB40	LB40	LB40	LB40	LB40
Compatible rotation unit	Type	KRM30	KRM30	KRM35	KRM40	KRM50	KRM60	KRM60	KRM60	KRM60	KRM70	KRM70

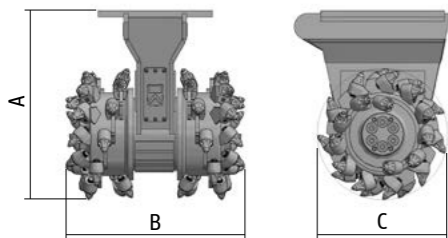

- 1 ER15/29/26/14C
- 2 ER16/46/38/20C
- 3 ER12/45/38/22 HC
- 4 ER17/75/70/30 Q
- 5 ER19/75/70/30 Q

<sup>[1]</sup> Setting the correct oil flow ensures that maximum output power is never greater than the rated power at any pressure level.

<sup>[2]</sup> For an overview of standard picks, see pages 49 to 51. Depending on application, cutter drums can be supplied with a choice of pick according to the type of pick box used.

<sup>[3]</sup> An overview of hole patterns can be found on page 54.



Direct drive



### APPLICATIONS

Demolition using long arm excavators

Ground stabilisation

Renovating concrete

Also used for trenching and pipeline work, profiling, mining soft minerals, underwater excavations, tunnelling and shaft sinking



KRD 120 | Profiling excavation boundaries



KRD 150 | Excavation work



Additional applications in KEMROC Projector

[projector.kemroc.net/web/?range=krd](http://projector.kemroc.net/web/?range=krd)

# KRC RANGE

## Bullhead cutters with full-face coverage for narrow trenches

 7–80 t

The KRC range of Bullhead cutters have two cutter drums arranged at an angle to one another so that the two sets of picks provide full face coverage without any gap between them, eliminating the need to swing the cutter from side to side. Operating the

cutter without sideways movement creates a trench with the same width as the cutter attachment.

Compared to the EK range of chain cutters, which also have full-face coverage thanks to the central cutter

chain, the KRC range of bullhead cutters are easier to maintain. However, due to their design, they cannot achieve the extreme narrow trenching widths of the EK chain cutters.



Exceptional narrow width due to special design gearbox

Powerful hydraulics thanks to double motor design

Excavate narrow trenches without sideways movement

Ideal for soil stabilisation

Protected hose management

Operational to 30 meters underwater without need for modifications



**KRC 40**   **KRC 60**   **KRC 100**   **KRC 110**   **KRC 140**   **KRC 150**   **KRC 160**   **KRC 220**   **KRC 240**

		KRC 40	KRC 60	KRC 100	KRC 110	KRC 140	KRC 150	KRC 160	KRC 220	KRC 240
Recommended excavator weight	t	7–11	12–17	18–30	20–32	25–40	35–50	35–55	50–70	55–80
Rated power	kW	40	60	100	110	140	150	160	220	240
Cutter length (A)	mm	980	1,200	1,390	1,390	1,520	1,520	1,520	1,860	1,860
Cutting width (B)	mm	530	600	810	810	880	880	880	1,200	1,200
Average cutter drum diameter (C)	mm	415	545	650	650	700	700	700	925	925
Recommended rotation speed	rpm	110	85	70	70	75	75	75	50	50
Recommended oil flow <sup>[1]</sup>	l/min	80	115	205	255	265	330	360	520	560
Max. oil flow <sup>[1]</sup>	l/min	110	155	230	285	300	360	360	610	630
Max. operating pressure	bar	400	400	400	400	400	400	400	400	400
Torque at 380 bar	Nm	4,800	9,100	15,700	19,400	24,200	30,200	32,700	60,500	65,300
Cutting force at 380 bar	kN	23	33	48	60	69	86	93	131	141
Max. rock compressive strength	MPa	30	50	80	80	100	100	120	140	140
Weight	kg	475	800	1,400	1,400	2,000	2,000	2,000	4,300	4,300
Tool holder / pick box	Type	PH 20	PH 22	PH 32 HD	PH 32 HD	PH 32 HD	PH 32 HD	PH 32 HD	PH 38 HD	PH 38 HD
Number of picks	Pcs	60	56	52	52	52	52	52	68	68
Standard pick <sup>[2]</sup>	Type	1	2	3	3	3	4	4	5	5
Standard hole pattern <sup>[3]</sup>	Type	LB 10	LB 20	LB 30	LB 30	LB 40	LB 40	LB 40	LB 40	LB 40
Compatible rotation unit	Type	KRM 35	KRM 40	KRM 50	KRM 50	KRM 60	KRM 60	KRM 70	KRM 80	KRM 80

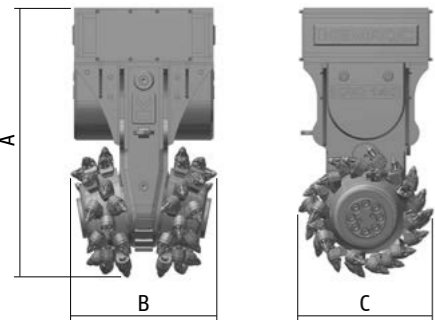

- 1 ER 16/46/38/20 C
- 2 ER 15/46/38/22 C
- 3 ER 17/75/70/30 Q
- 4 ER 19/75/70/30 Q
- 5 ER 25/80/80/38 C

<sup>[1]</sup> Setting the correct oil flow ensures that maximum output power is never greater than the rated power at any pressure level.  
<sup>[2]</sup> For an overview of standard picks, see pages 49 to 51. Depending on application, cutter drums can be supplied with a choice of pick according to the type of pick box used.  
<sup>[3]</sup> An overview of hole patterns can be found on page 54.



### APPLICATIONS

Trenching and pipeline work  
Soil stabilisation



KRC 150 | Trenching and pipeline work



KRC 100 | Trenching and pipeline work



Additional applications in KEMROC Projector

[projector.kemroc.net/web/?range=krc](http://projector.kemroc.net/web/?range=krc)



# DMW RANGE

Cutter wheels with double motor for rock up to 140 MPa

 14–120 t

Cutter wheels in the DMW range were designed in cooperation with customers for attachment to hydraulic excavators. Two high torque, lateral hydraulic motors guarantee high production rates and maximum cutting forces. As a result, even in hard rock with a uniaxial compressive strength of 140 MPa as well as reinforced concrete, very high productivity rates can be achieved. KEMROC produces these robust attachments in four sizes for excavators from 14 to 120 tons.

To meet the demands of many applications, KEMROC have developed cutter wheel variations for cutting depths to 1,000 millimeters. A choice of wheels with different tooling configurations and a range of widths up to 400 mm are available. Wheels with non-standard width and cutting depth are available on demand.

The DMW range is designed to work under water to depths of 30 meters, making the cutter wheels ideal for trenching and underwater demolition projects.

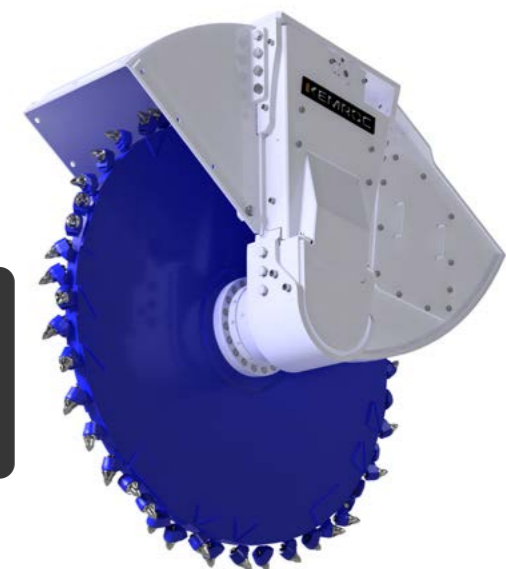

**DMW 220**  
Bridge demolition using the Cut & Break process

## Cutter wheels with double motor for rock up to 140MPa

Two high torque hydraulic motors  
Smooth and regular cutting action

Cutter wheels for various cutting depths and widths  
Supports for vibration free cutting

Optional – water nozzles for dust suppression  
Operational to 30 meters underwater

		DMW 90			DMW 130			DMW 220			DMW 240			DMW 400
		Wheel 400	Wheel 600	Wheel 400	Wheel 600	Wheel 800	Wheel 600	Wheel 800	Wheel 1000	Wheel 600	Wheel 800	Wheel 1000	Wheel 1000	
Recommended excavator weight	t	14–25	14–25	20–40	20–40	25–40	40–60	40–60	45–60	40–60	40–60	45–60	50–70 <sup>[5]</sup>   70–120	
Rated power	kW	90	90	130	130	130	220	220	220	220	220	220	400	
Cutting depth (A)	mm	400	600	400	600	800	550	750	1,000	550	750	1,000	1,000	
Cutting width (B)	mm	80 130 200	80 130 200	80 130 200	80 130 200	80 130 200	130 200 400	130 200 400	130 200 400	130 200 400	130 200 400	130 200 400	150 200 400	
Cutter wheel diameter	mm	1,210	1,610	1,210	1,610	2,010	1,610	2,010	2,570	1,610	2,010	2,570	2,700	
Recommended rotation speed	rpm	90	80	80	80	60	55	55	50	50	50	45	40	
Recommended oil flow <sup>[1]</sup>	l/min	170	150	320	320	250	550	550	500	550	550	500	900	
Max. oil flow <sup>[1]</sup>	l/min	200	200	340	340	340	650	650	650	650	650	650	1,200	
Max. operating pressure	bar	400	400	400	400	400	400	400	400	400	400	400	400	
Torque at 380 bar	Nm	11,300	11,300	24,500	24,500	24,500	59,500	59,500	59,500	65,300	65,300	65,300	142,600	
Cutting force at 380 bar	kN	19	14	41	31	24	74	59	46	81	65	51	106	
Max. rock compressive strength	MPa	60	40	100	80	60	120	120	100	120	120	100	140	
Weight of drive unit, approx.	kg	1,100	1,100	1,150	1,150	1,400	2,750	2,750	2,750	2,750	2,750	2,750	5,500	
Weight of dipping device, approx.	kg	250	250	300	300	550	920	920	920	920	920	920	1,450	
Weight of protection cover, approx.	kg	55	55	55	55	55	180	180	180	180	180	180	250	
Weight of cutter wheel <sup>[2]</sup>	kg	400	800	400	800	1,500	800	1,250	2,250	800	1,250	2,250	3,300	
Total weight <sup>[2]</sup>	kg	1,805	2,205	1,905	2,305	3,505	4,650	5,100	6,100	4,650	5,100	6,100	10,500	
Tool holder / pick box <sup>[3]</sup>	Type	PH 38 HD	PH 38 HD	PH 38 HD	PH 38 HD	PH 38 HD	PH 38 HD	PH 38 HD	PH 38 HD	PH 38 HD	PH 38 HD	PH 38 HD	PH 38 HD	
Number of picks	Pcs	30	40	30	40	50	40	42	50	40	42	50	62	
Standard pick <sup>[3]</sup>	Type	1	1	1	1	1	2	2	2	2	2	2	3	
Standard hole pattern <sup>[4]</sup>	Type	LB 30	LB 30	LB 30	LB 30	LB 30	LB 40	LB 40	LB 40	LB 40	LB 40	LB 40	LB 50	
Compatible rotation unit	Type	KRM 50	KRM 50	KRM 60	KRM 60	KRM 60	KRM 80	KRM 80	KRM 80	KRM 80	KRM 80	KRM 80	—	

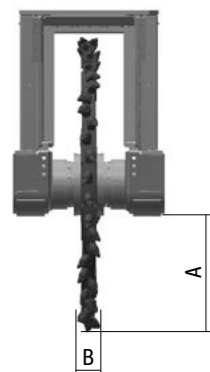

- 1 ER 17/75/70/30 Q
- 2 ER 22/75/70/30 Q
- 3 ER 25/80/80/38 C

- [1] Setting the correct oil flow ensures that maximum output power is never greater than the rated power at any pressure level.
- [2] Cutter wheel weight depends on diameter and width.
- [3] Contrary to what is shown in the table, 80 mm wide cutter wheels are fitted with PH 22 pick boxes and ER 15/46/38/22 C picks as standard. For an overview of standard picks, see pages 49 to 51. Depending on application, cutter wheels can be supplied with a choice of pick according to the type of pick box used.
- [4] An overview of hole patterns can be found on page 54.

[5] Attachment only with special adaptor to boom and additional counterweight on excavator.

KEMROC can supply wheels to order for various cutting widths and depths. Within technical boundaries, cutter wheels can be made to order.



### APPLICATIONS

- Concrete demolition
- Cable trenching
- Tunnelling
- Soft rock mining



DMW 220 | Cutting stress relieving slots



DMW 130 | Tunnelling



DMW 220 | Demolition of reinforced concrete structures using the Cut & Break process

Additional applications in KEMROC Projector



projector.kemroc.net





# KRX RANGE

Powertool drives with attachments for milling, drilling and mixing

 5-50 t

The new range of KRX Powertool drives are extremely robust and use a high torque radial piston motor to generate extremely high torque and cutting forces. Designed for use with a selection of sturdy attachments, they are an ideal addition to your excavator for a wide variety of applications.

Used with a cutter attachment, the KRX drive can be used in trenching, cutting out foundations or for profiling bored pile heads. With a heavy duty hexagonal shaft connection, different attachments can be exchanged quickly and easily.

Milling attachments fitted with dragtooth tools can be used in permafrost or for tree stump grinding. Dragtooth cutters can also be used for mixing and soil stabilisation.

When used with a drilling attachment, the Powertool drive can drill shallow holes up to 1,500 millimeters diameter. With heavy duty bearings and an oversized hexagonal shaft connection, these tools are extremely strong and capable of drilling rock with uniaxial compressive strengths up to 60 MPa.

 **KRX 120**  
Working bored pile heads



## Powertool drives with attachments for milling, drilling and mixing

Multifunctional and versatile thanks to a large selection of attachments

Quick interchangeability of attachments



### APPLICATIONS

#### Milling attachment

- Excavating foundations
- Profiling bored pile heads
- Tree stump grinding (dragontooth)

Also suitable for use in trenching, mixing soil formations and for cleaning slag out of runners in steel works

#### Drilling attachment

- Enlarging holes for sheet pile ramming
- Drilling holes for I-beam shoring
- Drilling planting holes for trees
- Exploratory drilling for ordnance disposal services
- Drilling foundations for sound barriers

#### Drive

Base drive unit without attachment



#### Milling attachment

Longitudinal cutter head with round attack or dragon tooth picks



Longitudinal cutter head with spiral extension



#### Drilling attachment

Drilling auger with pilot bit



#### Attachments for wood

Surface peeler for tree stumps



Conical splitter



**KRX 30** **KRX 45** **KRX 65** **KRX 68** **KRX 70** **KRX 120** **KRX 130** **KRX 140** **KRX 150**

		KRX 30	KRX 45	KRX 65	KRX 68	KRX 70	KRX 120	KRX 130	KRX 140	KRX 150
Recommended excavator weight	t	5-8	9-12	13-20	15-23	15-25	25-40	25-40	30-50	35-50
Rated power	kW	30	45	65	65	70	120	120	140	140
Length of drive unit	mm	550	610	610	610	830	842	842	875	875
Torque at 380 bar	Nm	4,400	6,100	11,300	14,700	16,300	29,800	34,000	36,400	43,000
Max. idle oil flow	l/min	110	130	190	190	300	360	360	390	420
Max. operating pressure	bar	400	400	400	400	400	400	400	400	400
Weight without attachment	kg	160	240	260	260	520	540	540	900	900
Hex connection, standard	mm	80	80	80	80	160	160	160	160	160
Standard hole pattern <sup>[2]</sup>	Type	LB 10	LB 20	LB 20	LB 20	LB 30	LB 30	LB 30	LB 30	LB 40
<b>Milling attachment (optional)</b>										
Length of standard cutter head	mm	350	350	350	350	400	430	430	450	450
Diameter of standard cutter head	mm	370	400	400	400	450	520	520	550	550
Cutting force at 380 bar	kN	23.9	30.7	56.5	73.5	72.6	114.4	130.6	132.3	156.3
Recommended idle speed	rpm	80	65	90	70	70	65	60	60	55
Recommended idle oil flow	l/min	50-70	65-90	120-170	130-165	135-195	190-320	225-335	280-370	300-390
Weight of standard cutter head	kg	67	86	86	86	97	142	142	195	195
Total weight	kg	227	326	346	346	617	682	682	1,095	1,095
Tool holder / pick box	Type	PH 22	PH 22	PH 22	PH 22	PH 22	PH 32 HD	PH 32 HD	PH 32 HD	PH 32 HD
Number of picks	Pcs	26	29	29	29	30	25	25	30	30
Standard pick (round shaft) <sup>[1]</sup>	Type	1	1	1	1	1	3	3	5	5
Standard pick (dragon tooth) <sup>[1]</sup>	Type	2	2	2	2	2	4	4	4	4
<b>Drilling attachment (optional)</b>										
Max. drill diameter	mm	600	800	1,000	1,000	1,000	1,300	1,300	1,500	1,500
Min. drill diameter	mm	270	270	270	270	270	270	270	270	270
Max. drilling depth at max. drill diameter	mm	1,500	1,500	2,000	2,000	2,000	4,000	4,000	4,000	4,000
Max. drilling depth at min. drill diameter	mm	2,500	3,000	4,000	4,000	7,000	7,000	7,000	8,000	8,000
Max. uniaxial compressive strength of the ground	MPa	10	20	20	20	30	50	50	60	60
Recommended idle oil flow	l/min	30-65	35-80	80-150	80-145	105-195	175-295	195-310	220-350	250-390

1 ER 12/45/38/22 HC  
2 DT 22/46/38/22 HC

3 ER 17/75/70/30 Q  
4 DT 22/90/70/30 HQ

5 ER 19/75/70/30 Q

[1] For an overview of standard picks, see pages 49 to 51. Depending on application, cutter heads can be supplied with a choice of pick according to the type of pick box used.

[2] An overview of hole patterns can be found on page 54.

High torque radial piston motors  
Heavy duty, long lasting bearings  
Exceptionally robust hexagonal shaft connector



KRX 120 | Drilling holes in concrete retaining walls

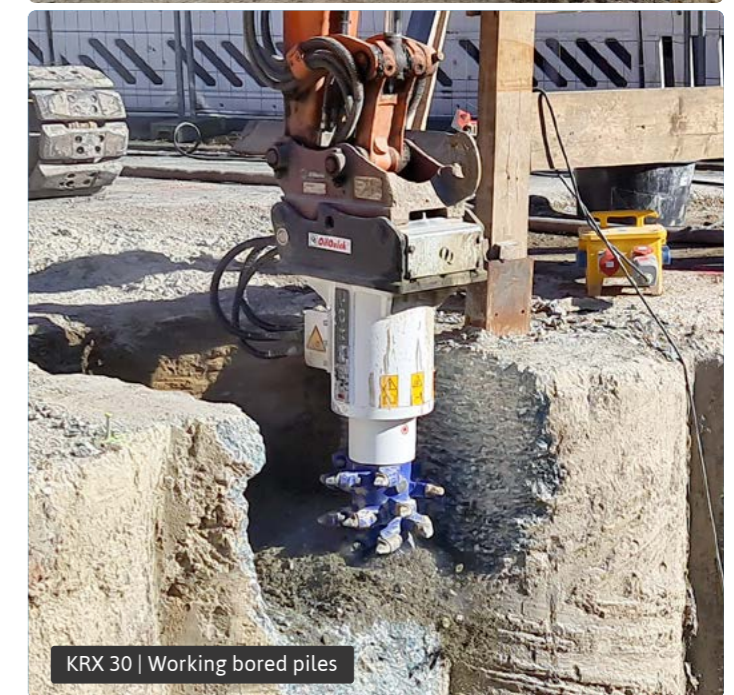

KRX 30 | Working bored piles



Additional applications in KEMROC Projector

[projector.kemroc.net/web/?range=krx](http://projector.kemroc.net/web/?range=krx)



## APPLICATIONS

- Repairing asphalt surfaces
- Removal of contaminated concrete surfaces
- Milling asphalt for house connections
- Milling walls and plaster removal
- Renovating locks
- Tunnel renovation



EX 45 HD | Tunnel renovation



EX 45 HD | Asphalt removal



Additional applications in KEMROC Projector

[projector.kemroc.net/web/?range=ex](http://projector.kemroc.net/web/?range=ex)



# EX RANGE

## Patch planers for milling asphalt and concrete with accurate depth control



1–25 t

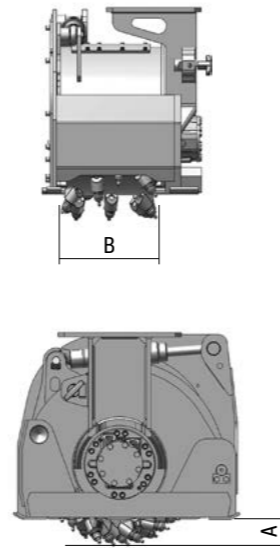

Patch planers in the EX range are ideally suited for the repair of asphalt surfaces, removal of contaminated concrete or milling layers of screed. Mechanical or hydraulic depth control makes milling to very accurate depth possible, to a maximum of 19 centimeters.

Regardless of whether horizontal, vertical or inclined – the EX range can be used on any surface orientation. KEMROC planers can even be used on overhead surfaces, as can be found for example, in some tunnelling

applications. Patch planers produce clean, smooth cut edges (pre-cutting is not necessary) and a fine grained cut material that can be used in other applications.

Depending on the material to be milled, cutter drums can be fitted with different tooling variations. In addition, non-standard drum types and widths can be supplied to meet unusual working conditions and ensure the best performance possible.

- +** A rigid support frame with wear resistant slides
- +** High torque, modifiable, hydraulic motor
- +** Robust housing, low vibration
- +** Accurate depth control (mechanical or hydraulic)
- +** Smooth cut edges and fine grained cut material
- +** Integrated water jets for dust control (connections for vacuum dust extraction optional)

**EX 20**    **EX 20 HD**    **EX 30 HD**    **EX 45 HD**    **EX 60 HD**    **EX 70 HD**

		EX 20	EX 20 HD	EX 30 HD	EX 45 HD	EX 60 HD	EX 70 HD
Recommended excavator weight	t	1–3	2–4	5–10	10–16	15–23	18–25
Rated power	kW	22	22	30	65	80	80
Cutting depth, adjustable (A)	mm	0–70	0–70	0–120	0–150	0–190	0–190
Cutting width (B)	mm	200	200	300	450	600	600
Cutter drum diameter	mm	360	360	525	580	675	675
Recommended rotation speed	rpm	160	160	110	100	105	80
Recommended oil flow <sup>[1]</sup>	l/min	40	50	80	155	175	250
Max. oil flow <sup>[1]</sup>	l/min	50	65	105	180	200	280
Max. operating pressure	bar	310	310	380	380	380	380
Torque at 350 bar <sup>[2]</sup>	Nm	800	1,000	4,100	8,700	9,300	17,900
Cutting force at 350 bar <sup>[2]</sup>	kN	4	6	15	30	28	53
Total weight	kg	165	182	420	730	1,230	1,230
Tool holder / pick box	Type	PH 14	PH 14	PH 20	PH 20	PH 20	PH 20
Number of picks	Pcs	42	42	35	49	69	69
Standard pick <sup>[3]</sup>	Type	1	1	2	2	3	3
Standard hole pattern <sup>[4]</sup>	Type	LB 10 <sup>[5]</sup>	LB 10 <sup>[5]</sup>	LB 10	LB 20	LB 20	LB 20
Compatible rotation unit	Type	KRM 20	KRM 20	KRM 30	KRM 30	KRM 30	KRM 30

- 1 ER 16/28/26/14 H
- 2 ER 16/48/32/20 H
- 3 ER 19/48/36/20 H

<sup>[1]</sup> Setting the correct oil flow ensures that maximum output power is never greater than the rated power at any pressure level.

<sup>[2]</sup> Models EX 20 and EX 20 HD designed for use at 205 bar.

<sup>[3]</sup> For an overview of standard picks, see pages 49 to 51. Depending on application, cutter drums can be supplied with a choice of pick according to the type of pick box used.

<sup>[4]</sup> An overview of hole patterns can be found on page 54.

<sup>[5]</sup> Plus AC-SB152 hole pattern.

# ES RANGE

## Cutter heads for asphalt, concrete and rock

 1–40 t

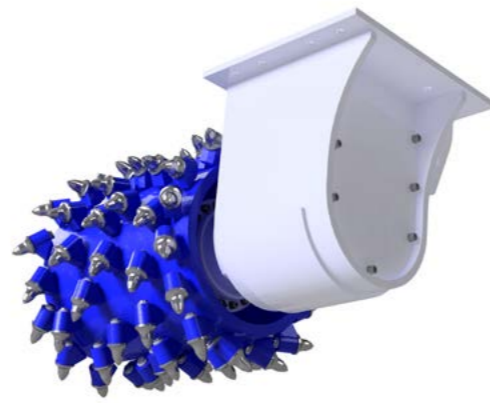

The ES range of cutter heads are ideally suited for accurate profiling of horizontal or vertical surfaces. Whether for surface cleaning, profiling, straightening or simply for

material removal, depending on the application, various types of cutter drum can be used for processing asphalt, concrete and rock.

ES cutter heads are available for excavators with 1 to 40 ton operating weight and can be used in conjunction with stepless rotation modules.

- + Tool carrier with high torque hydraulic motor
- + Milling attachment for the precise removal of material from horizontal and vertical surfaces
- + An integrated rotation unit, providing continuous stepless rotation, is available as an option

		ES 20	ES 20 HD	ES 30 HD	ES 45 HD	ES 60 HD	ES 70 HD
Recommended excavator weight	t	1–3	2–4	5–10	10–16	15–23	20–25
Rated power	kW	22	22	30	65	80	80
Cutter drum diameter (A)	mm	360	360	520	580	670	670
Cutting width (B)	mm	200	200	300	450	600	600
Cutting depth	mm	85	85	110	110	190	190
Min. rotation speed	rpm	85	85	80	65	90	55
Min. oil flow	l/min	20	25	60	100	150	180
Max. oil flow	l/min	70	90	110	180	210	210
Max. operating pressure	bar	310	310	400	400	400	400
Torque at 380 bar <sup>[1]</sup>	Nm	1,200	1,000	4,400	9,400	10,100	19,500
Cutting force at 380 bar <sup>[1]</sup>	kN	7	6	17	33	30	58
Weight of base drive unit	kg	80	80	125	270	280	280
Tool holder / pick box	Type	PH14	PH14	PH20	PH20	PH20	PH20
Number of picks	Pcs	42	42	35	49	69	69
Standard pick <sup>[2]</sup>	Type	ER16/28/26/14 H	ER16/28/26/14 H	ER16/48/32/20 H	ER16/48/32/20 H	ER16/48/32/20 H	ER16/48/32/20 H
Standard hole pattern <sup>[3]</sup>	Type	LB10 <sup>[4]</sup>	LB10 <sup>[4]</sup>	LB10	LB20	LB20	LB20

		ES 80 HD	ES 90 HD	ES 110 HD	ES 120 HD
Recommended excavator weight	t	15–25	20–30	25–40	25–40
Rated power	kW	80	80	110	120
Cutter drum diameter (A)	mm	825	825	785	785
Cutting width (B)	mm	600 800	600 800	600 800 1,000	600 800 1,000
Cutting depth	mm	150	150	105 150	105 150
Min. rotation speed	rpm	60	55	45	45
Min. oil flow	l/min	150	180	210	230
Max. oil flow	l/min	210	210	350	350
Max. operating pressure	bar	400	400	400	400
Torque at 380 bar <sup>[1]</sup>	Nm	15,200	19,500	27,200	32,600
Cutting force at 380 bar <sup>[1]</sup>	kN	37	47	69	83
Weight of base drive unit	kg	580	580	1,115	1,115
Tool holder / pick box	Type	PH32 HD	PH32 HD	PH32 HD	PH32 HD
Number of picks per cutting width	Pcs	50 69	50 69	46 53 62	46 53 62
Standard pick <sup>[2]</sup>	Type	ER17/75/70/30 HQ	ER17/75/70/30 HQ	ER19/75/70/30 HQ	ER19/75/70/30 HQ
Standard hole pattern <sup>[3]</sup>	Type	LB30	LB40	LB40	LB40

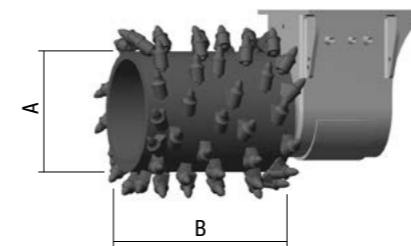
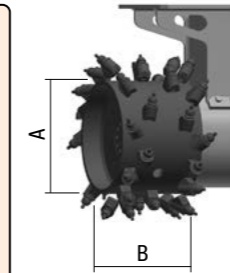



### APPLICATIONS

- Grinding jet grouting material
- Lock renovation
- Grinding retaining walls
- Profiling blocks of natural stone
- Grinding shotcrete in tunnels
- Cleaning concrete piled walls



<sup>[1]</sup> Models ES 20 and ES 20 HD designed for use at 205 bar.  
<sup>[2]</sup> For an overview of standard picks, see pages 49 to 51. Depending on application, cutter drums can be supplied with a choice of pick according to the type of pick box used.  
<sup>[3]</sup> An overview of hole patterns can be found on page 54.  
<sup>[4]</sup> Plus AC-SB152 hole pattern.

An overview of compatible rotation units for the ES range can be found on pages 42 to 43.



Additional applications in KEMROC Projector

[projector.kemroc.net/web/?range=es](https://projector.kemroc.net/web/?range=es)



## APPLICATIONS

- Pre-drilling for rammed sheet piles
- Drilling holes for I-beam shored walls
- Drilling holes for tree planting
- Exploration drilling for ordnance disposal services

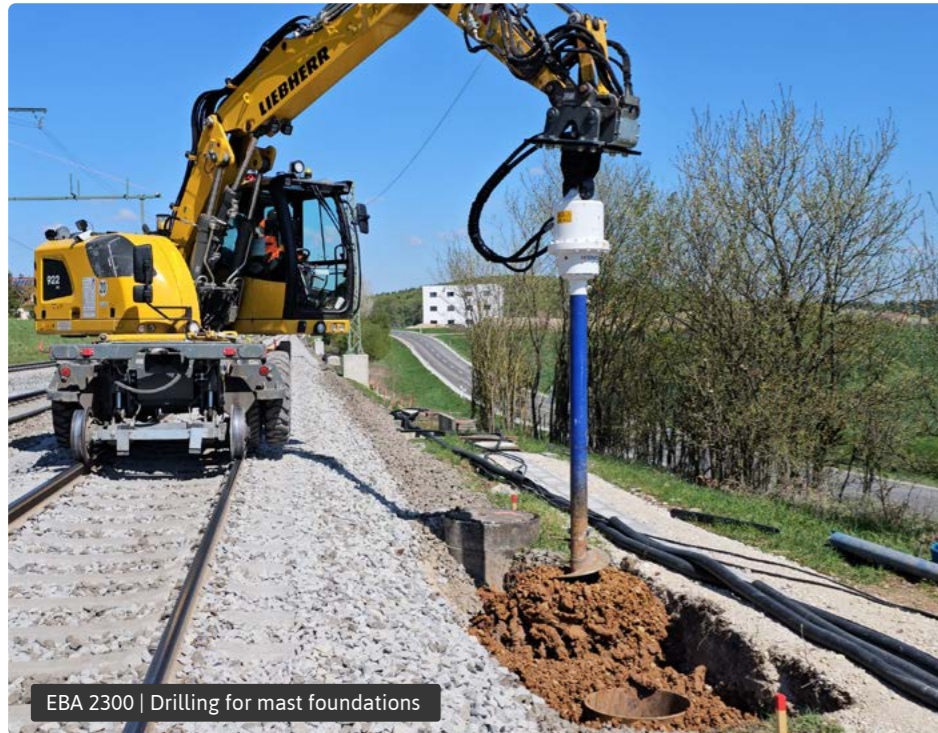

EBA 2300 | Drilling for mast foundations



EBA 2300 | Drilling for support shoring

EBA 2800 | Drilling for support shoring

Short and heavy duty construction

Robust and rigid bracket

Direct drive without planetary gears

Robust hexagonal shaft connector

Wear resistant augers

Auger drives for tough applications

# EBA RANGE

## Auger drive attachments for excavators and backhoe loaders

7-40 t

The EBA range of auger drive units allows you to quickly convert your excavator or backhoe loader into a drill rig by simply changing the attachment.

These auger drive units are ideal for drilling holes in soft to compact soils, cobbles and in soft rock with compressive strengths up to 50 MPa.

For use in harder rock, KEMROC have developed special drilling tools to ensure higher drilling speeds.



	EBA 500	EBA 750	EBA 1000	EBA 1500	EBA 2300	EBA 2800	EBA 3300
--	---------	---------	----------	----------	----------	----------	----------

Recommended excavator weight	t	7-13	7-15	14-17	16-20	18-35	20-40	25-40
Rated power	kW	41	41	65	65	110	150	160
Diameter of drive unit (A)	mm	390	390	390	390	500	500	500
Length of drive unit (B)	mm	645	645	645	645	990	990	990
Recommended rotation speed <sup>[1]</sup>	rpm	75	65	65	60	70	65	60
Recommended oil flow <sup>[1][2]</sup>	l/min	50-70	60-80	80-120	100-150	150-320	180-330	220-340
Max. oil flow <sup>[2]</sup>	l/min	85	85	150	150	360	360	360
Max. operating pressure	bar	400	400	400	400	400	400	400
Torque at 350 bar	Nm	5,200	7,300	11,300	14,700	27,200	30,300	34,000
Cutting force at 350 bar	kN	52.0	73.4	112.9	146.8	181.3	201.8	226.5
Weight	kg	160	160	180	180	360	360	360
Auger connection	Type	H 80	H 80	H 80	H 80	H 80	H 80	H 80
Tool holder / pick box	Type	PH 22	PH 22	PH 22	PH 22	PH 22	PH 22	PH 22
Standard pick	Type	1	1	1	1	1	1	1
<b>Drilling attachment (optional)</b>								
Max. drill diameter	mm	800	800	1,000	1,000	1,200	1,500	1,500
Min. drill diameter	mm	200	200	200	200	300	300	300
Max. drilling depth with max. drill diameter	mm	2,000	2,000	3,000	3,000	4,000	4,000	4,000
Max. drilling depth with min. drill diameter	mm	5,000	5,000	5,000	5,000	8,000	8,000	8,000
Max. rock compressive strength	MPa	50	50	50	50	50	50	50

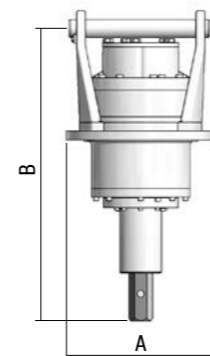

1 ER 22/46/38/22 H

<sup>[1]</sup> Recommended oil flows and rotation speeds depend on the drill bit diameter.

<sup>[2]</sup> Setting the correct oil flow ensures that maximum output power is never greater than the rated power at any pressure level.



### Notes for drilling with KEMROC auger drive units:

When mounted on an excavator arm, the augers are not supported in a feeder. Due to the natural curve of the excavator arm, augers can be bent during drilling. Therefore, special care must be taken to ensure that the augers are always working vertically. Only by keeping the auger in the vertical position can you guarantee a straight bore hole. Take great care to avoid bending the augers. Excessive bending of the auger can result in the hex drive breaking and damage to the auger drive. Select the auger rotation speed that corresponds to the auger diameter and material being drilled. Generally, rotation speeds should be lower for larger diameter augers or when drilling in harder material.



Additional applications in KEMROC Projector

[projector.kemroc.net/web/?range=eba](http://projector.kemroc.net/web/?range=eba)



# KTR RANGE

## Trenching attachments for medium hard rock

 18–35 t



The KTR range of trenchers can produce trenches with perfect profiles in widths from 17 to 45 centimeters to a maximum depth of 1.8 meters. Chose from a range of cutting chain widths, each fitted with wear resistant picks.

When starting the trench, the KTR is supported while sumping down to the desired cutting depth. When the trencher has reached the required depth, the excavator is driven backwards or the trencher

is pulled forward with the excavator arm. Finally, the milled material is transported via a special discharge housing or screw conveyor and deposited next to the trench.

- + Driven by two high torque hydraulic motors to obtain maximum cutting force
- + Housing with spoil discharger and sumping aid
- + Adjustable length cutter chain
- + Maintenance free cutter chain with high operating life

### KTR 65

### KTR 120

Recommended excavator weight	t	18–25	25–35
Rated power	kW	65	120
Cutting depth (A)	mm	1,000–1,500	1,000–1,800
Cutting width (B)	mm	170–350	200–450
Recommended chain speed	m/s	2.0–2.5	2.0–2.5
Recommended oil flow <sup>[1]</sup>	l/min	190	300
Max. oil flow <sup>[1]</sup>	l/min	230	360
Max. operating pressure	bar	400	400
Torque at 380 bar	Nm	12,100	27,200
Cutting force at 380 bar	kN	48	94
Max. rock compressive strength	MPa	50	60
Weight at max. cutting depth and width	kg	1,700	2,700
Tool holder / pick box	Type	PH 22	PH 22
Standard pick <sup>[2]</sup>	Type	ER 12/45/38/22 HC	ER 12/45/38/22 HC
Standard hole pattern <sup>[3]</sup>	Type	LB 30	LB 30
Compatible rotation unit	Type	KRM 50	KRM 60
Recommended chain slack	mm	130	180

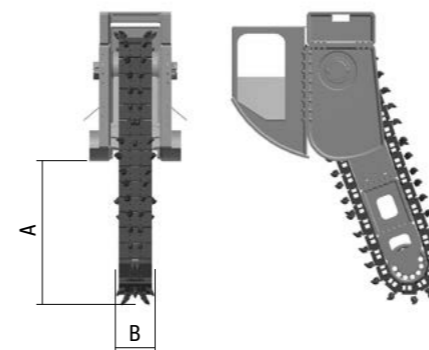

<sup>[2]</sup> For an overview of standard picks, see pages 49 to 51. Depending on application, cutter chains can be supplied with a choice of pick according to the type of pick box used.

<sup>[3]</sup> An overview of hole patterns can be found on page 54.

<sup>[1]</sup> Setting the correct oil flow ensures that maximum output power is never greater than the rated power at any pressure level.



KTR 65 | Trenching and pipeline work

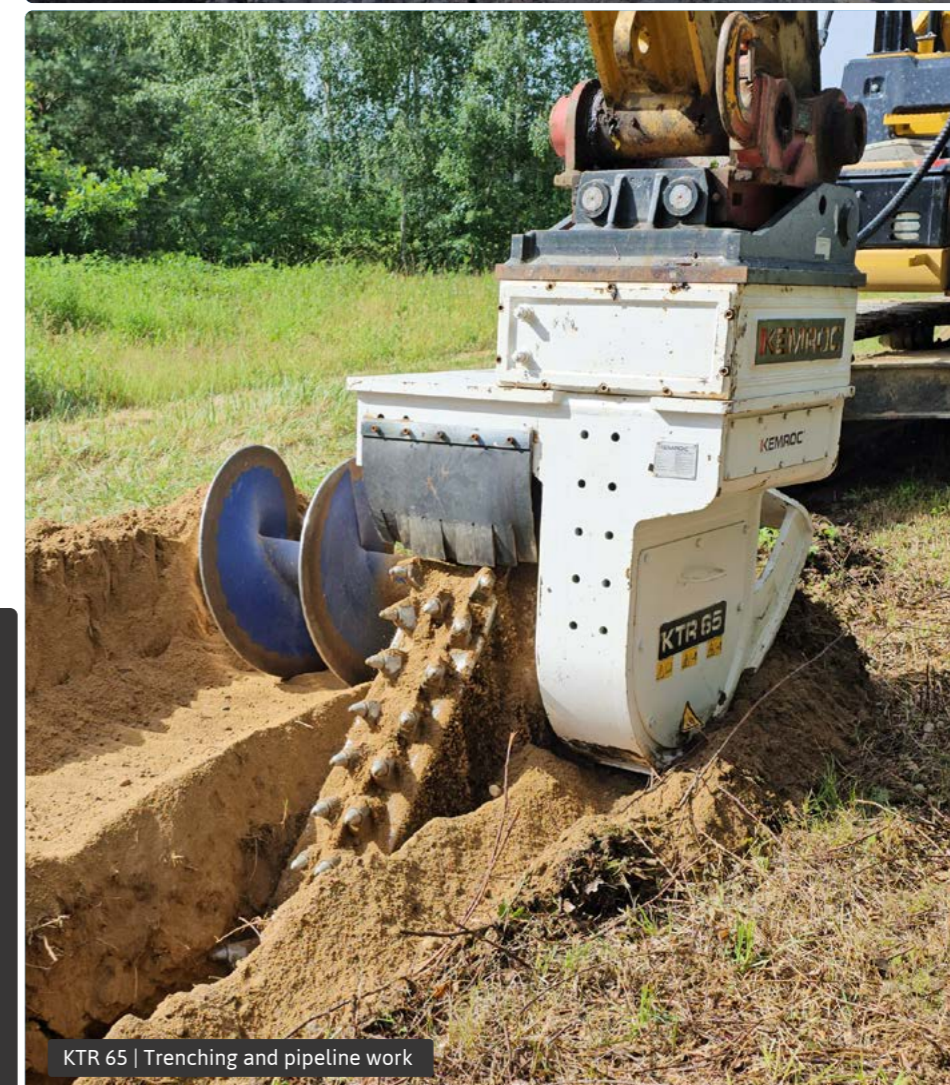

KTR 65 | Trenching and pipeline work



KTR 130 | Trenching and pipeline work



### APPLICATIONS

Trenching and pipeline work

Additional applications in KEMROC Projector



[projector.kemroc.net/web/?range=ktr](http://projector.kemroc.net/web/?range=ktr)



# KDS RANGE

Diamond saws for a wide variety of applications and materials

 1–50 t

The KDS range of diamond saws are designed for cutting a variety of materials including natural stone, concrete, reinforced concrete, asphalt, plastics, wood, paper, sheets, steel and aluminium. Mounted on crawler or wheeled excavators or backhoe loaders and connected to their on-board hydraulics, they deliver high performance levels in many applications with very little burden for the machine, the operator or the environment. High rotation speeds and a good selection of diamond saw blades enable them to cover a wide range of applications very efficiently.

From road construction to precision demolition and on to high-performance recycling—KDS diamond saws are robust, reliable and economical in all applications.

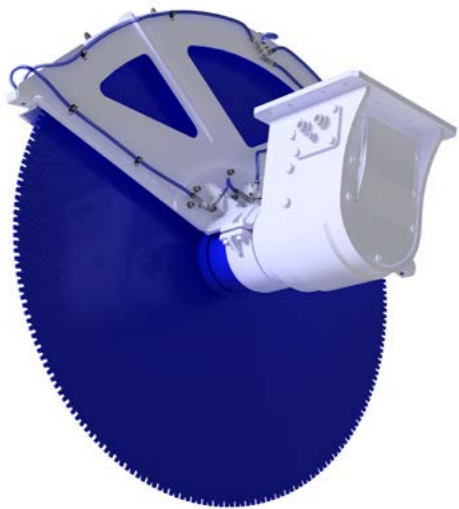

**KDS 50**  
Cutting stainless steel tubes

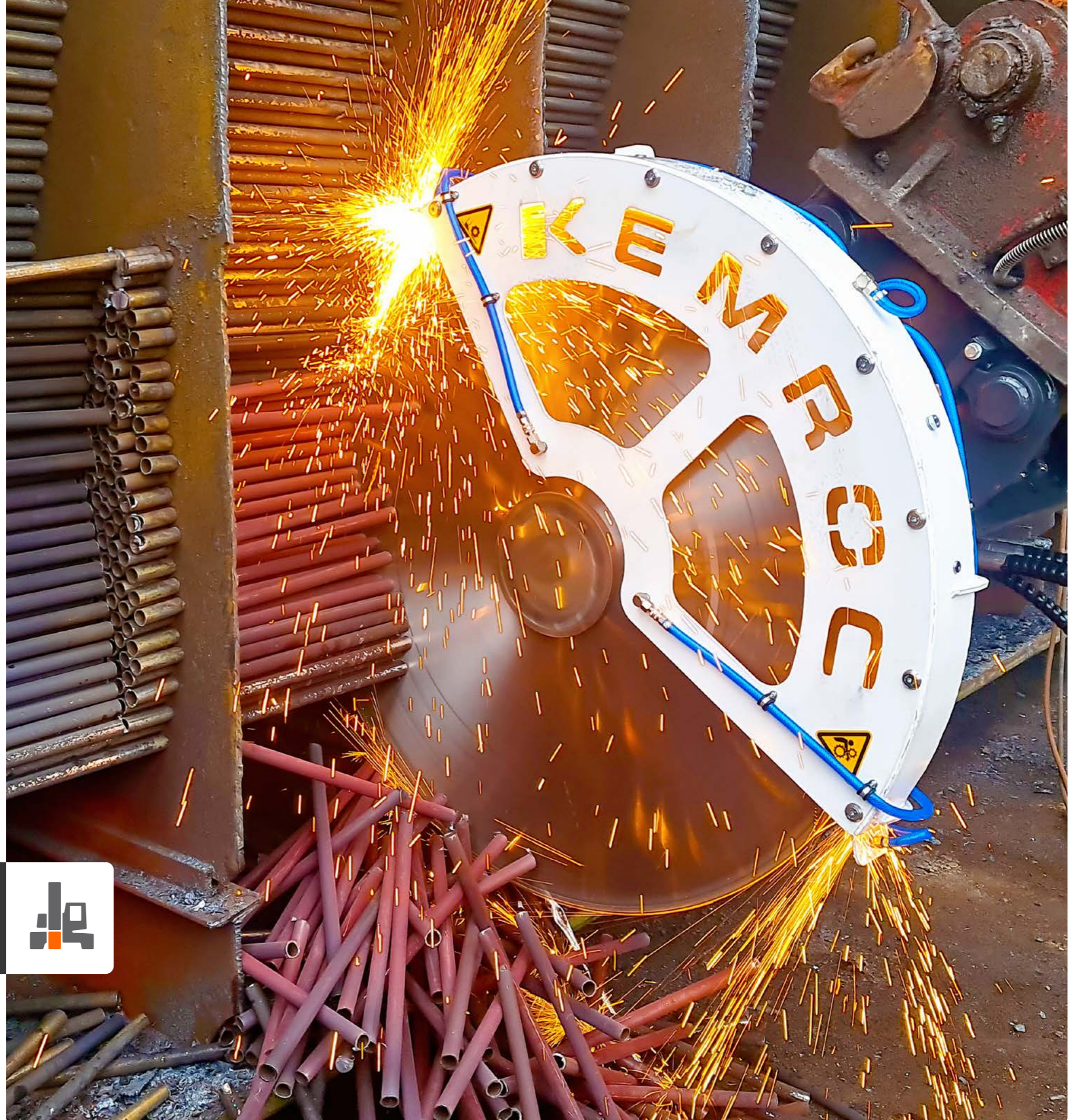

Diamond saws for a wide variety of applications and materials

High rotation speed up to 2,000 rpm  
Drive motors with heavy-duty bearings

Lateral pull-out protective covers for all saw blade diameters

Effective cooling of saw blades

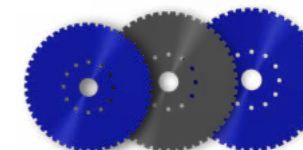

		KDS 15	KDS 20	KDS 30	KDS 40	KDS 50	KDS 50 HD	KDS 60	KDS 70
Recommended excavator weight	t	1-3	2-5	5-14	10-16	14-30	18-35	20-40	25-50
Max. rated power	kW	23	23	38	70	85	181	240	344
Max. saw blade diameter (A)	mm	1,000	1,000	1,400	1,600	2,000	2,000	2,500	3,000
Max. rotation speed	rpm	1,100	1,100	1,100	1,100	1,100	1,100	950	850
Recommended rotation speed	rpm	690-1,050	730-1,000	550-1,000	480-1,000	380-900	390-1,000	310-920	250-810
Recommended oil flow <sup>[1]</sup>	l/min	15-25	25-35	30-55	50-110	50-115	110-280	160-485	200-650
Max. operating pressure	bar	350	350	350	350	350	350	350	350
Torque at 350 bar	Nm	100	200	300	600	700	1,600	2,900	4,500
Weight of drive unit, approx.	kg	105	105	250	340	420	450	600	650
Standard hole pattern <sup>[2]</sup>	Type	LB10	LB10	LB10	LB20	LB20	LB20	LB30	LB30
Compatible rotation unit	Type	KRM20	KRM20	KRM30	KRM30	KRM30	KRM30	KRM30	KRM30

### Saw blades for:

Natural stone, concrete and reinforced concrete

Asphalt, GRP, airplanes

Steel

Wood, plastic, paper rolls, foil rolls, aluminum

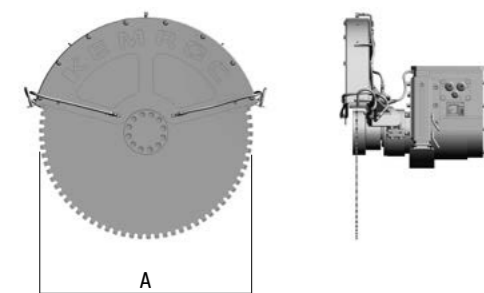

<sup>[1]</sup> The recommended oil flow depends on the material being cut and the saw blade diameter.  
<sup>[2]</sup> An overview of hole patterns can be found on page 54.

An overview of saw blades can be found on page 53.



### APPLICATIONS

- Cutting rotor blades from wind turbines
- Cutting asphalt in road works
- Demolition of reinforced concrete
- Cutting aluminium sheets
- Cutting wood
- Cutting natural stone such as limestone, sandstone, etc



KDS 50 | Cutting concrete



KDS 30 | Cutting asphalt



KDS 50 HD | Recycling wind turbine components

Additional applications in KEMROC Projector



[projector.kemroc.net/web/?range=kds](http://projector.kemroc.net/web/?range=kds)



# KRM RANGE

## Rotation units with endless rotation

 2-70t



- Compact and low maintenance
- Continuous and stepless rotation
- High holding torques
- Durable worm gear drive
- Heavy duty bearings
- Save up to 50 percent working time
- Oil distributors developed in-house guarantee flow rates of oil and water

Rotation units in the KRM range have been developed for use with KEMROC milling attachments. In combination with rotation units, milling attachments can always be placed in the correct position while facing in the right direction. As a result, in most cases work is completed faster and with more accuracy.

When used with EX patch planers, it is possible to mill longitudinally in front of the excavator as well as 90° across the excavator without having to move the excavator. You can even work to the side of the excavator. DMW, EK or KTR attachments working in combination with KRM rotation units can also benefit from this flexibility of working

position. Horizontal slots can be cut easily using a KDS attachment together with a KRM rotation unit.

Depending on the application, productivity can be increased by up to 50 percent when using KRM rotation units – especially in sewer and pipeline construction, profiling and tunnelling.



### APPLICATIONS

- Trenching and pipeline work
- Tunnelling
- Demolition and renovation
- Profiling



KRM 50 | Trenching and pipeline work



KRM 60 | Foundation work

		KRM 20	KRM 30	KRM 35	KRM 40	KRM 50	KRM 60	KRM 70	KRM 80
Recommended excavator weight	t	2-6	5-12	7-15	12-18	19-27	25-40	30-50	50-70
Diameter (A)	mm	240	370	370	460	570	600	700	900
Height (B)	mm	330	371	371	405	430	610	620	820
Length (C)	mm	350	500	500	555	690	780	910	1,170
Width (D)	mm	510	610	610	805	860	770	870	1,000
Recommended idle speed	rpm	9	7	5	3	1	1	1	1
Max. idle oil flow	l/min	40	40	40	40	40	40	40	40
Max. operating pressure	bar	160	160	160	160	160	160	160	160
Max. holding torque	Nm	6,000	9,000	18,000	45,000	95,000	200,000	270,000	350,000
Total weight	kg	138	335	387	493	629	910	1,028	2,068
Number of drive motors	Pcs	1	1	2	2	2	2	2	2
Standard hole pattern <sup>[1]</sup>	Type	LB 10	LB 10 20 30	LB 10 20 30	LB 20	LB 30	LB 40	LB 40	LB 40
<b>Recommended KEMROC attachments</b>									
EK Chain Cutters	Type		EK 20	EK 40	EK 60	EK 100	EK 110 140 150	EK 160	EK 220 240
EKT Rotary Drum Cutters	Type		EKT 20	EKT 40	EKT 60	EKT 100	EKT 110 140 150	EKT 160	EKT 220 240
KR Rotary Drum Cutters	Type		KR 18 20	KR 35	KR 45 50 65 70	KR 80	KR 110 120 150	KR 165 175	KR 200 250
KRD Rotary Drum Cutters	Type		KRD 18	KRD 30	KRD 45	KRD 70	KRD 100 120 150	KRD 165	
KRC Bullhead Cutters	Type				KRC 60	KRC 100	KRC 110 140 150	KRC 160	KRC 220 240
DMW Cutter Wheels	Type					DMW 90	DMW 130		DMW 220
EX Surface Milling Attachments	Type	EX 20	EX 30 45 60 70						
ES Cutter Heads	Type	ES 20	ES 30		ES 45	ES 60 70 80 90	ES 110 120		
KTR Trenching Attachments	Type					KTR 65	KTR 120		
KDS Diamond Saw Attachments	Type	KDS 15 20 30	KDS 40 50 60 70						

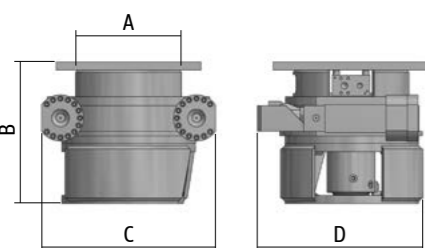

<sup>[1]</sup> An overview of hole patterns can be found on page 54.



Additional applications in KEMROC Projector

[projector.kemroc.net/web/](http://projector.kemroc.net/web/)

# NON-STANDARD MODELS

Manufactured to order according to customer requirements

**+** Non-standard attachments that can be produced according to specific customer requirements.

## Cutter drums with double motor

High torque and cutting force characterise milling cutter drums with double motor in the DMD range. They feature an adjustable milling depth setting and are ideally suited for milling and profiling concrete surfaces, natural stone, rock walls, and tunnel profiles. DMD cutter drums are available for excavators from 8 to 50 tons.

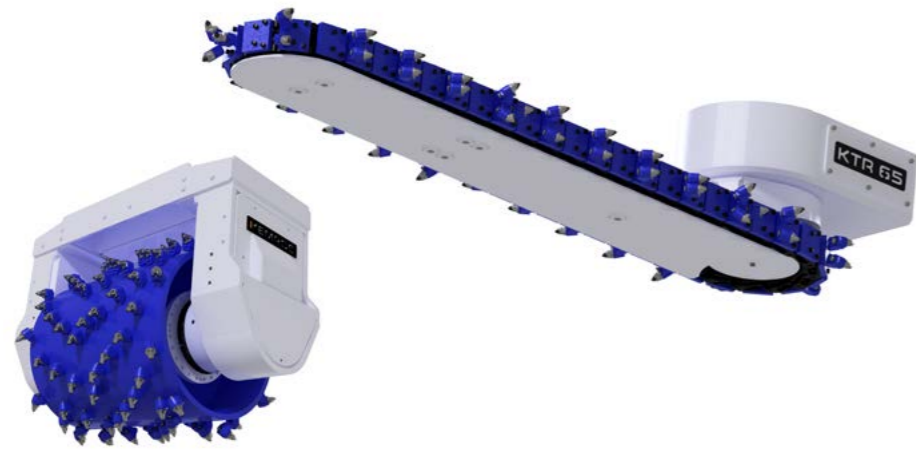

## Track bed cleaners

The GBR range of track bed cleaners are attachments specifically designed for clearing ballast from under railway tracks and for removing loose materials such as those accumulating under conveyor belts.

The attachments are for tracked or mobile excavators weighing 18 to 35 tons. Clearing heights vary from 170 to 450 millimeters.

## Cutter wheels for narrow trenching

The SMW range is designed for use as an excavator slot cutting attachment. It can cut narrow trenches, especially for laying cables, quickly and efficiently. The reinforced mounting for the cutter wheel provides the strength required for cutting depths down to 1,000 millimeters.

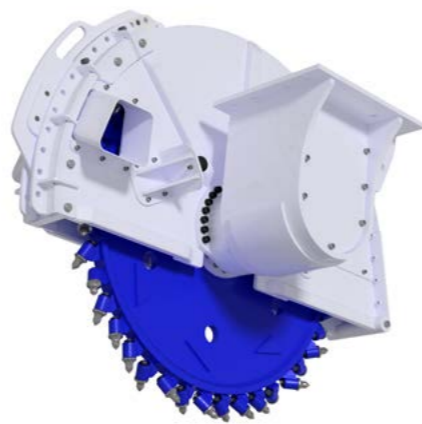

## Trenching attachments for soils and soft rock

The KTS range of trenchers can be used for producing clean, correctly profiled trenches quickly in cohesive soils as well as in soft rocks with uniaxial compressive strengths up to a maximum of 20 MPa.

Trenchers are designed for use on excavators from 2.5 to 10 tons and can be mounted on skid steer loaders with a suitable adaptor bracket.



## Grinding attachments for wood and removal of tree stumps

The range of KST wood grinders can remove tree stumps cleanly, quickly and effectively. Models, available for use on excavators from 2 to 25 ton operating weight as well as backhoe and skid steer loaders, can operate with rotation speeds up to 2,000 rpm.

Due to the design of the cutter disk, hard wood can be ground very effectively as well as soft woods.

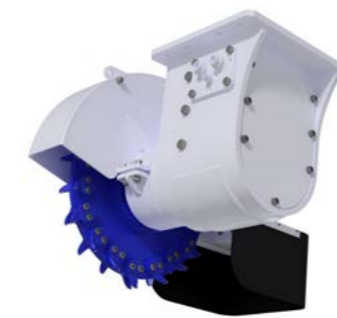

## Cleaning head attachments for use on flat surfaces

The EXRUST range of cleaning head attachments were developed by KEMROC to clean flat metal surfaces such as those found in the holds of cargo ships.

The drums rotate at a speed of 800 rpm. During operation, a specially made chain removes paint or other materials from the metal surface.



DMD | Surface profiling



SMW | Cable trenching with vacuum extractor



KTS | Trenching and pipeline work



EXRUST | Cleaning steel surfaces

Special foundation solutions from Kemsolid Division — fast, efficient and environmentally friendly



Sealing walls, dam stabilisation, and basin renovation for flood protection

Soil improvement and ground stabilisation



Decontamination and remediation

Shoring excavations for building, civil engineering and pipeline construction



Barrier installation, surface renovation, slope and embankment work in road building

Railway construction



## Kemsolid TSM solution

The TSM or Trench Soil Mixing technology is a process used to produce soil-cement structures that function as cut-off, retaining and shoring walls, as well as for soil stabilisation as an alternative to the installation of concrete columns or piles.

KSI soil mixing attachments for Kemsolid TSM solution are available in four sizes for mounting on excavators or piling rigs. Depending on the model, they can be produced with blades for mixing depths from 4 to 16 meters and for different mixing widths.

		KSI 7000	KSI 12000	KSI 12000 W	KSI 16000
Carrier type	Type	Excavator	Excavator / Rig	Excavator / Rig	Excavator / Rig
Recommended excavator weight	t	35–55	80–120 <sup>[1]</sup>	80–120 <sup>[1]</sup>	120–200 <sup>[2]</sup>
Recommended rig weight	t	—	50–70	50–70	60–100
Rated power	kW	130	220	220	300
Mixing depth	m	4 5 6 7	6 7 8 9 10 11 12	4 6 8	6 8 10 12 14 16
Mixing width	mm	350–500	500–650	400–1.050	450–950
Recommended oil flow	l/min	280–350	490–620	600–750	660–820
Weight at max. mixing depth and max. mixing width	kg	4,900	13,500	12,500	21,000

<sup>[1]</sup> KSI 12000 and KSI 12000 W: Use on 50 to 80 ton excavators possible with special adaptor.  
<sup>[2]</sup> KSI 16000: Use on 75 to 120 ton excavators possible with special adaptor.

## Kemsolid MSM solution

Mass Soil Mixing (MSM) technology is a process for soil improvement and stabilisation. Depending on the requirements, slurry, concrete or a dry binder is mixed mechanically with the soil in-situ for stabilisation and solidification.

Mixing attachments in the KDM range are available in five sizes for 25 to 50 ton excavators. Due to the range of mixing drums available and extension possibilities, a variety of mixing widths and depths can be achieved.

		KDM 120	KDM 150	KDM 155	KDM 165	KDM 175
Recommended excavator weight	t	25–40	30–40	30–40	35–50	35–50
Rated power	kW	120	150	155	165	175
Cutter length	mm	1,155	1,155	1,155	1,200	1,200
Mixing width	mm	1,100 1,300	1,300 1,500	1,500	1,400 1,700	1,700 2,000
Recommended oil flow	l/min	300	325	340	360	400
Weight per mixing width	kg	1,550 1,700	1,700 1,800	1,800	2,250 2,500	2,500 2,700

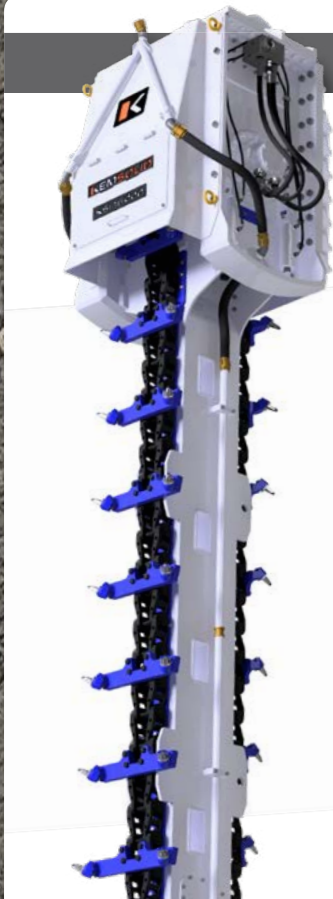

[kemsolid.com](http://kemsolid.com)



More information in the Kemsolid brochure



# TOOLS

**Picks with matching retainers**

**Pick boxes**

**Diamond saw blades**

**Mounting and dismantling tools**

---

KEMROC cutters and cutting wheels work under extremely hard conditions in trenching, demolition, rock excavation and tunnelling, in steel mills as in other unusual applications. This puts very high demands on the cutter drums and cutting tools.

The result of many years experience, with machines working around the world, can be seen in the type of picks used and their placement on the drums. This unique combination provides maximum productivity with minimum wear, ensuring the economical performance of KEMROC products even in the hardest conditions.

Modern technology and continuous product development are the basics for ensuring the economic benefits of using our cutting tools and attachments. In our range of cutter picks, we have paid special attention to the optimum shape, high quality materials and sustainable quality of the production process. This helps you to keep your consumable costs to a minimum.

The following pages are intended to provide an overview of our standard range of picks, retainers and pick boxes suitable for the majority of applications.

In addition to alternative design cutter drums, we also offer a large variety of pick types even for unusual applications. If you have an extremely unusual application or requirement, don't hesitate to contact us. Our specialists are pleased to provide advice and support in your search for the most suitable cutter tools.

## Simple facts about picks

### PICKS

The tungsten carbide insert braised into the body of the pick is at the heart of the cutting operation and is subject to extreme stresses due to it coming continuously into contact with the rock. The pick body (head and shaft) is made from heat-treated steel and serves as the support for the tungsten carbide insert and also as protection for the pick box.

The tungsten carbide insert is extremely wear resistant and tough to withstand impact. The insert is a sintered material made up of tungsten carbide with a cobalt binder. Depending on application, a variety of carbide grades and shapes are available.

**Pick dimensions can be found from the numbers in the four-part numbering system:**

- |             |   |
|-------------|---|
| XX/xx/xx/xx | 1. Number: Diameter of tungsten carbide insert (mm) |
| xx/XX/xx/xx | 2. Number: Length of the head of the pick (mm)      |
| xx/xx/XX/xx | 3. Number: Diameter of pick shoulder (mm)           |
| xx/xx/xx/XX | 4. Number: Diameter of shaft of the pick (mm)       |

#### Example:

- Round attack pick ER 19/75/70/30 Q:
- |  |       |
|--|-------|
| 1. Number - Diameter of tungsten carbide insert: | 19 mm |
| 2. Number - Length of the head of the pick:      | 75 mm |
| 3. Number - Diameter of pick shoulder:           | 70 mm |
| 4. Number - Diameter of shaft of the pick:       | 30 mm |

### THE RETAINER

Retaining clips ensure that picks do not fly out of the pick boxes. Various types of retaining clip are available depending on pick type and application area e.g. retaining collars for soft rock or circlip type systems for hard rock applications.

For quick and easy changing of picks, KEMROC offers the QuickSnap retaining system, which allows picks to be changed in a matter of seconds. This represents a saving of over 50 percent in time compared with normal circlip or knock on retainer systems. Due to the deeper groove in the shaft of the pick and the larger surface area between pick and holder, the KEMROC QuickSnap system is more secure and has less wear.

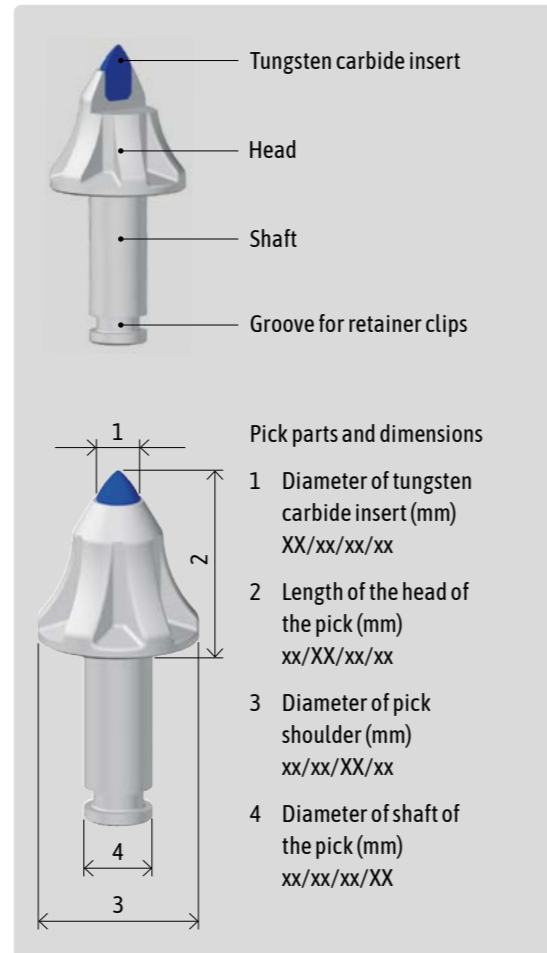

Pick parts and dimensions

- 1 Diameter of tungsten carbide insert (mm)  
XX/xx/xx/xx
- 2 Length of the head of the pick (mm)  
xx/XX/xx/xx
- 3 Diameter of pick shoulder (mm)  
xx/xx/XX/xx
- 4 Diameter of shaft of the pick (mm)  
xx/xx/xx/XX



Easier and quicker pick changes with KEMROC QuickSnap.

## Picks with matching retainers

### PH 14



Round attack pick  
ER 15/29/26/14 C  
incl. ES 14

Application  
Asphalt, concrete, soft to medium hard rock

Part No. 15292614



Round attack pick  
ER 16/28/26/14 H

Application  
Asphalt, concrete, soft to medium hard rock

Part No. 16282614

### PH 15



Round attack pick  
ER 19/33/30/15 S

Application  
Asphalt, concrete, soft to medium hard rock

Part No. 19333015



Circlip retainer  
SG 15

Part No. 99999990

### PH 20



Round attack pick  
ER 12/45/38/20 K

Application  
Concrete, soft to medium hard rock

Part No. 12453821



Round attack pick  
ER 19/48/36/20 H

Application  
Asphalt

Part No. 19483620



Round attack pick  
ER 16/46/38/20 C

Application  
Concrete, soft to medium hard rock

Part No. 16463820



Retaining clip  
ES 20

Part No. 99999991



Round attack pick  
ER 16/48/32/20 H

Application  
Asphalt

Part No. 16483220



## Picks with matching retainers

### PH 22



Round attack pick  
**ER 12/45/38/22 HC**

Application  
Concrete, medium hard and abrasive rock

Part No. 12453823



Retaining clip  
**ES 22**

Part No. 99999996



Round attack pick  
**ER 15/46/38/22 C**

Application  
Concrete, medium hard rock

Part No. 15463822



Retaining clip  
**ES 22**

Part No. 99999996



Round attack pick  
**ER 19/51/45/22 H**

Application  
Asphalt, soft and abrasive rock

Part No. 19514522



Dragontooth pick  
**DT 22/46/38/22 HC**

Application  
Soft and abrasive ground and rock, wood

Part No. 22463822



Retaining clip  
**ES 22**

Part No. 99999996

### PH 25



Round attack pick  
**ER 17/64/60/25 Q**

Application  
Concrete, medium hard rock

Part No. 17646026



QuickSnap<sup>[1]</sup>  
**QS 25**

Part No. 99250025



Round attack pick  
**ER 17/64/60/25 C**

Application  
Concrete, medium hard rock

Part No. 17646025



Retaining clip  
**ES 25**

Part No. 99999994



Round attack pick  
**ER 19/64/60/25 Q**

Application  
Concrete, medium hard rock

Part No. 19646026



QuickSnap<sup>[1]</sup>  
**QS 25**

Part No. 99250025



Round attack pick  
**ER 22/64/60/25 H**

Application  
Asphalt, soft and abrasive rock

Part No. 22646025



Dragontooth pick  
**DT 22/58/46/25 K**

Application  
Soft and abrasive ground and rock, wood

Part No. 22465825

### PH 30 | 30 HD | 32 HD



Round attack pick  
**ER 17/75/70/30 Q**

Application  
Concrete, medium hard rock

Part No. 17757036



QuickSnap<sup>[1]</sup>  
**QS 30**

Part No. 99500030



Round attack pick  
**ER 19/75/70/30 Q**

Application  
Concrete, medium hard rock

Part No. 19757035



QuickSnap<sup>[1]</sup>  
**QS 30**

Part No. 99500030



Round attack pick  
**ER 22/75/70/30 Q**

Application  
Concrete, medium hard to hard rock

Part No. 22757032



QuickSnap<sup>[1]</sup>  
**QS 30**

Part No. 99500030



Round attack pick  
**ER 30/77/70/29 Q**

Application  
Asphalt, soft, medium hard and abrasive rock

Part No. 30777032



QuickSnap<sup>[1]</sup>  
**QS 30**

Part No. 99500030



Round attack pick  
**ER 25/80/80/38 C**

Application  
Concrete, medium hard to very hard rock

Part No. 25808039



Retaining clip  
**ES 38**

Part No. 99500034

**NEW: Triple-plane milling teeth**  
For better rotation in soft rock



Round attack pick  
**ER 17/75/70/30 HD TP Q**

Application  
Soft and medium hard rock

Part No. 17757037



QuickSnap<sup>[1]</sup>  
**QS 30**

Part No. 99500030



Round attack pick  
**ER 19/75/70/30 HD TP Q**

Application  
Soft and medium hard rock

Part No. 19757036



QuickSnap<sup>[1]</sup>  
**QS 30**

Part No. 99500030



Round attack pick  
**ER 15/90/70/30 Q**

Application  
Salt, gypsum, medium hard, fractured rock

Part No. 15907035



QuickSnap<sup>[1]</sup>  
**QS 30**

Part No. 99500030

**Only suitable for PH 32 HD**



Dragontooth pick  
**DT 22/90/70/30 HQ**

Application  
Soft and abrasive rock, wood

Part No. 22907030



QuickSnap<sup>[1]</sup>  
**QS 30**

Part No. 99500030

<sup>[1]</sup> QuickSnap QS 30 is the standard retainer for this pick. Retaining clip ES 30 available as an alternative.



Retaining clip  
**ES 30**

Part No. 99500032

## Pick boxes

Pick boxes welded onto the cutter head or cutter wheel determine where and how picks penetrate into the rock. The special attack angle ensures a continuous rotation of the pick creating a self sharpening action for the tungsten carbide insert during the cutting action. The correct angle ensures maximum productivity with minimum wear.

Pick boxes are made from specially heat treated steel and depending on applications, are available with exchangeable wear sleeves.

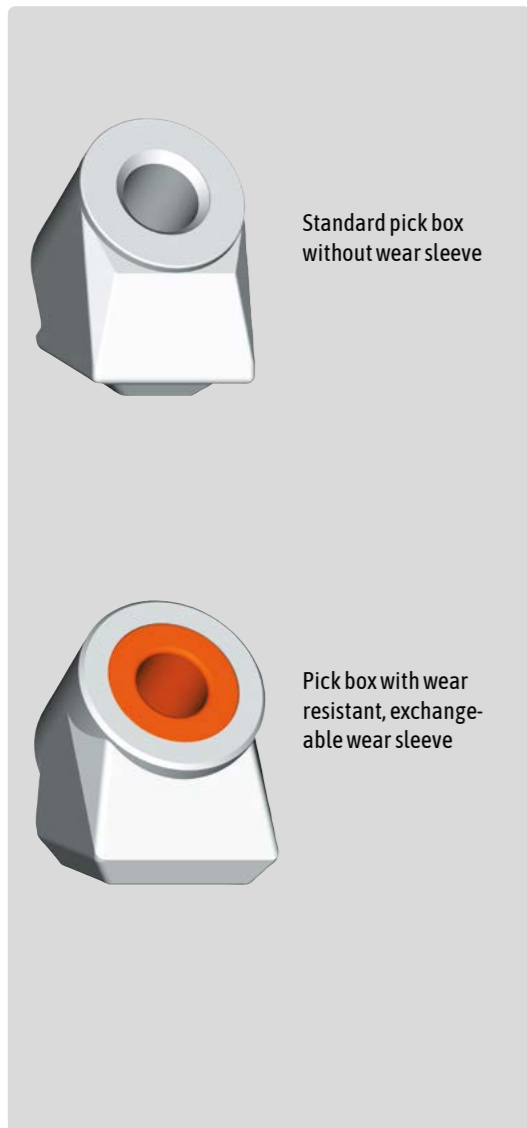

Standard pick box without wear sleeve

Pick box with wear resistant, exchangeable wear sleeve



Pick box  
**PH 14**

Part No. 711222



Pick box  
**PH 15**

Part No. 791004E

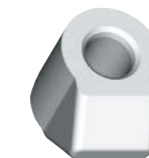

Pick box  
**PH 20**

Part No. 721024E



Pick box  
**PH 22**

Part No. 721025UA



Pick box  
**PH 25**

Part No. 761025UA

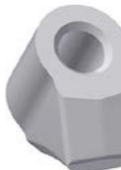

Pick box  
**PH 30**

Part No. 711610



Pick box  
**PH 30 HD**

Part No. 711084



Replacement wear sleeve

Part No. 711029



Pick box  
**PH 32 HD**

Part No. 711039



Replacement wear sleeve

Part No. 711029



Pick box  
**PH 38 HD**

Part No. 753022



Replacement wear sleeve

Part No. 753021

## Saw blades for the KDS range



**Diamond saw blades for Natural stone, concrete and reinforced concrete**

Diameter 800 mm

Diameter 1,000 mm

Diameter 1,200 mm

Diameter 1,400 mm

Diameter 1,500 mm

Diameter 1,600 mm

Diameter 1,800 mm



**Carbide tipped saw blades für wood, plastic, paper rolls, foil rolls, aluminum**

Diameter 400 mm

Diameter 600 mm

Diameter 900 mm

Diameter 1,000 mm

Diameter 1,100 mm



**Diamond saw blades for Asphalt, GFR, airplanes**

Diameter 800 mm

Diameter 1,000 mm

Diameter 1,200 mm

Diameter 1,400 mm

Diameter 1,500 mm

Diameter 1,600 mm

Diameter 1,800 mm



**Diamond saw blades for steel**

Diameter 600 mm

Diameter 800 mm

Diameter 1,000 mm

Diameter 1,200 mm

## Mounting and dismantling tools



**Knock-out tool**

For picks with shaft diameter 20–30 mm as for all dragtooth picks

Part No. 99999995



**Mounting tool for retaining clips**

For retaining clip ES 20  
Part No. 99999942

For retaining clip ES 22  
Part No. 99999947

For retaining clip ES 25  
Part No. 99999983

For retaining clip ES 30  
Part No. 99999939

For retaining clip ES 38  
Part No. 99999958



**Dismantling tool for retaining clips**

For retaining clip ES 20  
Part No. 99999943

For retaining clip ES 22  
Part No. 99999948

For retaining clip ES 25  
Part No. 99999982

For retaining clip ES 30  
Part No. 99999936

For retaining clip ES 38  
Part No. 99999959



**Puller tool for picks with retaining sleeves**

For picks with shaft diameter 20–25 mm  
Part No. 99999997



**Puller tool for QuickSnap retainers**

Part No. 99995000



**Mounting gripper for circlip retainers**

For picks with shaft diameter up to 25 mm  
Part No. 99999940

For picks with shaft diameter from 30 mm  
Part No. 99999946



**Knock-out tool for stuck picks**

For picks with shaft diameter 20–25 mm  
Part No. 99999938

For picks with shaft diameter 30–38 mm  
Part No. 99999937



# HOLE PATTERNS

Hole patterns for KEMROC attachments

## LB 10

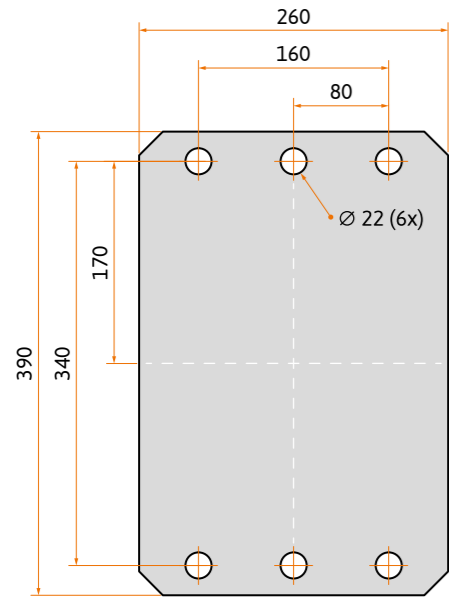

Excavator

## LB 30

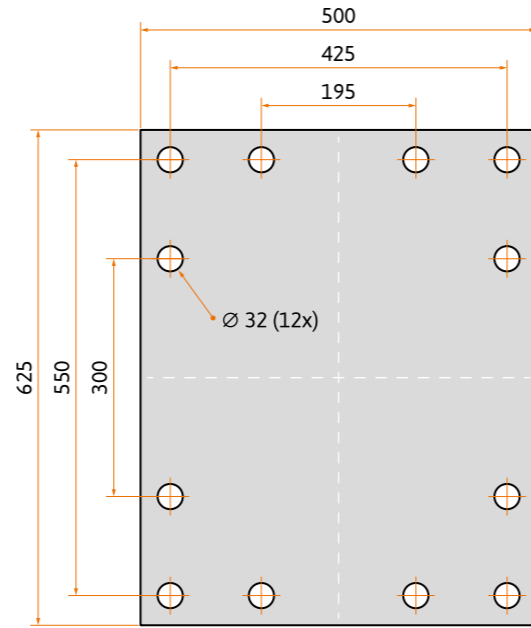

Excavator

## LB 50

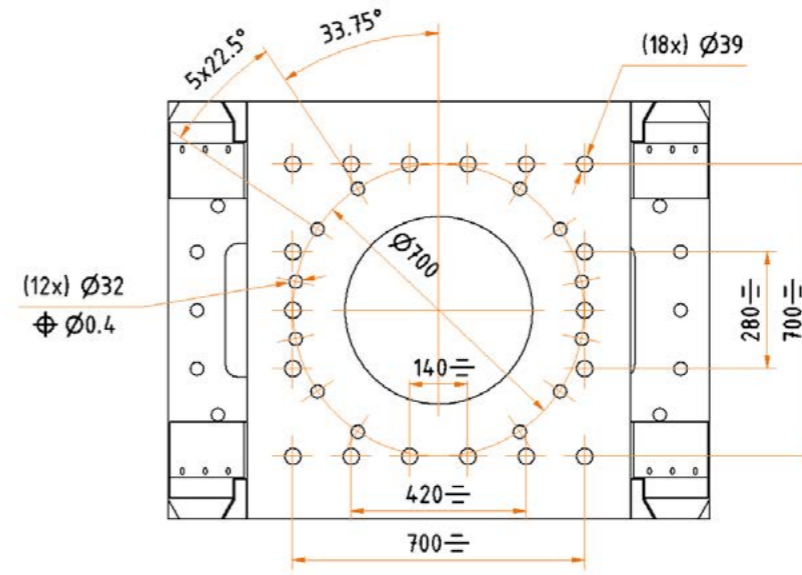

Excavator

## LB 20

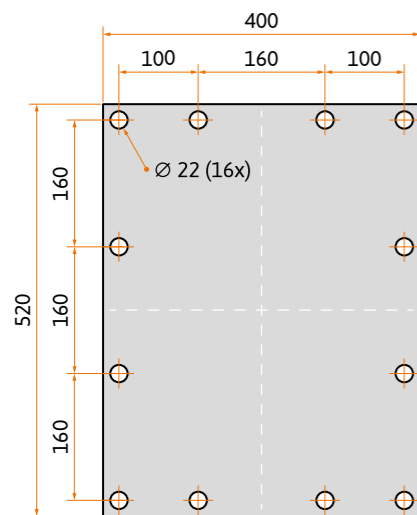

Excavator

## LB 40

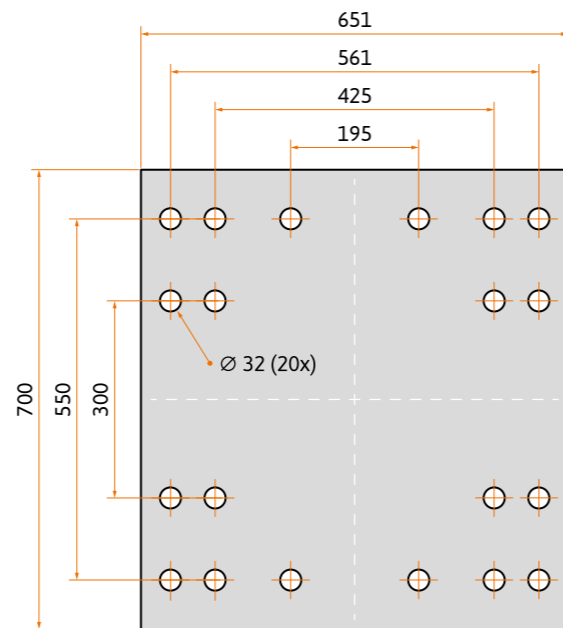

Excavator





Your local dealer



This catalogue is used to describe our products and accessories. The information contained in it does not imply any certified properties or indicate any suitability for certain or assumed purposes. Technical changes are reserved without prior announcement. We disclaim any liability arising from the illustrations and information in the catalogue and from all our representatives.

2026-06

[www.kemroc.com](http://www.kemroc.com)

**KEMROC Spezialmaschinen GmbH**  
Ahornstr. 6  
36469 Bad Salzungen  
Germany

Phone +49 3695 850 2550  
Fax +49 3695 850 2579  
E-mail [info@kemroc.de](mailto:info@kemroc.de)  
[www.kemroc.com](http://www.kemroc.com)

**KEMROC®**

revolution of cutting